

# **Amateur Radio Amateur Extra Class License Study Guide**

(For use July 1, 2002 to June 30, 2008)

Compliments of:

**Earl  
N8KBR**

**Source Material is Publicly Available**

(Source: Question Pool of 804 questions with graphics and CFR Title 47, Part 97, Amateur Radio Service.)

This document may be freely distributed and was developed for not-for-profit use only.

## Foreword

This document is simply a compilation of the publicly available question pool which has been converted into statements and formatted. The intent was to retain as much of the original words from the question pool as possible to leverage familiarization in the learning and memory process. The 15 terms most frequently used in the text are:

dB	signal	amateur
MHz	output	antenna
line	circuit	station
ohms	voltage	frequency
power	current	impedance

The author's hope is that this document might be useful as a resource in studying for the Element 4, Amateur Extra Class License Radio Exam.

## Table of Contents

<u>ELEMENT 4 SUBELEMENT</u>	<u>Page #</u>
SUBELEMENT E1 -- COMMISSION'S RULES.....	3
SUBELEMENT E2 -- OPERATING PROCEDURES.....	14
SUBELEMENT E3 -- RADIO WAVE PROPAGATION.....	19
SUBELEMENT E4 -- AMATEUR RADIO PRACTICES .....	22
SUBELEMENT E5 -- ELECTRICAL PRINCIPLES.....	28
SUBELEMENT E6 -- CIRCUIT COMPONENTS.....	39
SUBELEMENT E7 -- PRACTICAL CIRCUITS.....	46
SUBELEMENT E8 -- SIGNALS AND EMISSIONS.....	54
SUBELEMENT E9 -- ANTENNAS.....	59

**SUBELEMENT E1 -- COMMISSION'S RULES [7 Exam Questions -- 7 Groups]**

**Operating standards:**

**Frequency privileges for Extra class amateurs**

*Exclusive* frequency privileges authorized to Amateur Extra Class control operators in the:

40-meter band	7000-7025 kHz
20-meter band	14.000-14.025 MHz and 14.150-14.175 MHz
15-meter band	21.000-21.025 MHz and 21.200-21.225 MHz

The 80, 75, 40, 20 and 15 meters frequency bands contain at least one segment authorized to only control operators holding an Amateur Extra Class operator license.

Within the 20-meter band, 50 kHz is the amount of spectrum authorized to only control operators holding an Amateur Extra Class operator license.

The 80/75, 20 and 15 meters frequency bands contain two segments authorized to only control operators holding an Amateur Extra Class operator license, CEPT radio-amateur Class 1 license or Class 1 IARP.

**Emission standards**

An amateur station licensee must eliminate or reduce the interference if a spurious emission from the station causes harmful interference to the reception of another radio station.

The maximum mean power permitted to any spurious emission from a transmitter or external RF power amplifier transmitting at a mean power greater than 25 watts on an amateur service VHF band is 60 dB below the mean power of the fundamental emission.

The maximum mean power permitted for any spurious emission from a transmitter having a mean power of 25 W or less on an amateur service VHF band is the lesser of 25 microwatts or 40 dB below the mean power of the fundamental emission.

**Message forwarding**

If a packet bulletin board station in a message forwarding system inadvertently forwards a message that is in violation of FCC rules, the control operator of the originating station and conditionally the first forwarding station is accountable for the rules violation.

If your packet bulletin board station inadvertently forwards a communication that violates FCC rules, the first action you should take is discontinue forwarding the communication as soon as you become aware of it.

### **Frequency sharing between ITU Regions**

For each ITU Region, each frequency band is allocated internationally to the amateur service designated as primary service or secondary service.

### **FCC modification of station license**

The FCC might modify an amateur station license to promote the public interest, convenience and necessity.

### **30-meter band sharing**

The sharing requirements for an amateur station transmitting in the 30-meter band are it must not cause harmful interference to stations in the fixed service authorized by other nations.

### **Stations aboard ships or aircraft**

If an amateur station is installed on board a ship and is separate from the ship radio installation, its operation must be approved by the master of the ship before the station may transmit.

### **Telemetry**

Telemetry is a one-way transmission of measurements at a distance from the measuring instrument

### **Telecommand of an amateur station**

Telecommand is a one-way transmission to initiate, modify or terminate functions of a device at a distance.

### **Authorized telecommand transmissions**

When sending telecommand messages to a station in space operation an amateur station may transmit special codes intended to obscure the meaning of messages.

### **Station restrictions:**

#### **Restrictions on station locations**

If the land may have environmental importance; or it is significant in American history, architecture or culture might restrict the physical location of an amateur station apparatus or antenna structure.

An Environmental Assessment must be submitted to the FCC must be done before an amateur station is placed within an officially designated wilderness area or wildlife preserve, or an area listed in the National Register of Historical Places.

#### **Restricted operation**

Outside of 1 mile distance from an FCC monitoring facility an amateur station may be located without concern for protecting the facility from harmful Interference.

If an amateur station causes interference to the reception of a domestic broadcast station with a receiver of good engineering design, the operation of the amateur station may be restricted on the frequency or frequencies used when the interference occurs.

### **Teacher as control operator**

An amateur operator may accept compensation for serving as the control operator of an amateur station used in a classroom only when the amateur operator is paid as an incident of a teaching position during periods of time when the station is used by that teacher as a part of classroom instruction at an educational institution.

Only an amateur operator accepting such pay as an incident of a teaching position during times when the station is used by that teacher as a part of classroom instruction may the operator accept compensation for serving as a control operator in a classroom at an educational institution.

### **Station antenna structures**

If an amateur antenna structure is located in a valley or canyon, the structure must be no higher than 200 feet above the ground level at its site.

Local authorities must reasonably accommodate amateur service communications and must constitute the minimum practicable regulation to accomplish the state or local authorities' legitimate purpose when legislating height and dimension restrictions for an amateur station antenna structure.

If you are installing an amateur radio station antenna at a site within 5 miles from a public use airport, you must evaluate the height of your antenna based on the FCC Part 17 regulations.

### **Definition and operation of remote control and automatic control**

A remotely controlled station is a station controlled indirectly through a control link.

Amateur stations used for remote control of model aircraft may not be operated under automatic control.

The use of devices and procedures for control so that the control operator does not have to be present at the control point is considered automatic control of a station.

The control operator responsibilities of a station under automatic control differ from one under local control in that under automatic control the control operator is not required to be present at the control point.

### **Control link**

A control link is the means of control between a control point and a remotely controlled station.

Control link is the term for apparatus to effect remote control between the control point and a remotely controlled station.

## **Reciprocal operating:**

### **Reciprocal operating authority/Purpose of reciprocal agreement rules**

An FCC authorization for alien reciprocal operation is an FCC authorization to the holder of an amateur license issued by certain foreign governments to operate an amateur station in the US.

Any non-US citizen holding an amateur service license issued by their government with which the US has a reciprocal operating arrangement is authorized for alien reciprocal operation in places where the FCC regulates the amateur service.

US citizens are not eligible for alien reciprocal operation. A US citizen holding a foreign amateur service license may never be authorized for alien reciprocal operation in places where the FCC regulates the amateur service.

Not being a citizen of the country that issued the amateur service license would disqualify a foreign amateur operator from being authorized for alien reciprocal operation in places where the FCC regulates the amateur service.

No special document is required before a Canadian citizen holding a Canadian amateur service license may reciprocal operate in the US.

### **Alien control operator privileges**

The frequency privileges authorized for alien reciprocal operation are those authorized to the alien by his country of citizenship, but not to exceed those authorized to Amateur Extra Class operators.

If the US and the alien amateur's home country have a multilateral or bilateral reciprocal operating agreement, a properly licensed alien amateur has operating privileges equivalent to those authorized by their home license, not to exceed the operating privileges of an Amateur Extra Class operator license.

A licensed alien amateur operator may be the control operator of an amateur station at any location where the amateur service is regulated by the FCC.

### **Identification**

A Canadian amateur station must include the letter-numeral indicating the station location after the Canadian call sign and the closest city and state once during the communication with the assigned call sign in the station identification announcement when operating in the US.

An alien operator must supply an additional identification in the form of the letter-numeral indicating the station location in the US included before their call and the closest city and state given once during the communication when operating in the US under an FCC authorization for alien reciprocal operation.

### **CEPT**

An operating arrangement, the CEPT agreement, allows an FCC licensed US citizen to operate in many European countries and alien amateurs from many European countries to operate in the US.

## **IARP**

A multilateral or bilateral operating arrangement, the IARP agreement, allows an FCC licensed US citizen and many Central and South American amateur operators to operate in each other's countries.

## **Radio Amateur Civil Emergency Service (RACES):**

### **Definition**

Radio Amateur Civil Emergency Service (RACES) is a radio service using amateur stations for civil defense communications during periods of local, regional, or national civil emergencies.

### **Purpose**

The purpose of RACES is to provide civil-defense communications during emergencies.

### **Station registration**

An amateur station must be registered with a civil defense organization before participating in RACES.

### **Station license required**

Any FCC-licensed amateur station certified by the responsible civil defense organization for the area served may be operated in RACES.

### **Control operator requirements**

Anyone who holds an FCC-issued amateur operator license and is certified by a civil defense organization may be the control operator of a RACES station.

### **Control operator privileges**

All amateur service frequencies otherwise authorized to the control operator are authorized normally to an amateur station participating in RACES.

### **Frequencies available**

Specific segments in the amateur service MF, HF, VHF and UHF bands are the frequencies authorized to an amateur station participating in RACES during a period when the President's War Emergency Powers are in force.

All frequencies authorized to the amateur service are normally available for RACES operation.

### **Limitations on use of RACES frequencies**

An emergency during which the President's War Emergency Powers are invoked can cause limits to be placed on the frequencies available for RACES operation.

## **Points of communication for RACES operation**

Amateur stations participating in RACES and specific other stations authorized by the responsible civil defense official may communicate.

## **Permissible communications**

Communications for National defense or immediate safety of people and property and communications authorized by the area civil defense organization are permissible in RACES.

## **Amateur Satellite Service:**

### **Definition/Purpose/Station license required for space station/Frequencies available**

The amateur-satellite service is a service using amateur stations on satellites for the purpose of self-training, intercommunication and technical investigations.

## **Telecommand operation:**

### **Definition/Eligibility**

Any amateur station so designated by the space station licensee is eligible to be telecommand stations.

### **Telecommand station (definition)**

A telecommand station in the amateur-satellite service is an amateur station that transmits communications to initiate, modify or terminate functions of a space station.

### **Space telecommand station/ Special provisions**

A unique privilege is afforded a telecommand station. A telecommand station may transmit command messages to the space station using codes intended to obscure their meaning.

## **Telemetry:**

### **Definition/Special provisions**

Telemetry is the term for space-to-Earth transmissions used to communicate the results of measurements made by a space station.

## **Space station:**

### **Definition**

A space station in the amateur-satellite service is an amateur station located more than 50 km above the Earth's surface.

### **Eligibility**

Any FCC-licensed amateur station is eligible to operate as a space station.

## **Special provisions**

A space station must be capable of effecting a cessation of transmissions by telecommand whenever so ordered by the FCC.

## **Authorized frequencies (space station)**

Only the 40m, 20m, 17m, 15m, 12m and 10m amateur service HF bands have frequencies authorized to space stations.

The 2 meter VHF amateur service band has frequencies available for space stations.

The 70 cm, 23 cm, 13 cm amateur service UHF bands have frequencies available for a space station.

## **Earth operation:**

### **Definition**

An earth station in the amateur-satellite service is an amateur station within 50 km of the Earth's surface for communications with Amateur stations by means of objects in space.

### **Eligibility/Authorized frequencies (Earth station)**

Any amateur station, subject to the privileges of the class of operator license held by the control operator is eligible to operate as Earth stations.

## **Volunteer Examiner Coordinators (VECs):**

### **Definition/ VEC qualifications/ VEC agreement/ Scheduling Examinations/ Coordinating VEs Reimbursement for expenses**

A Volunteer-Examiner Coordinator is an organization that has entered into an agreement with the FCC to coordinate amateur operator license examinations.

### **Accrediting VEs**

The VE accreditation process can be described as each VEC ensures that its Volunteer Examiner applicants meet FCC requirements to serve as VEs.

Persons who have ever had an amateur operator or amateur station license suspended or revoked seeking to be VEs cannot be accredited.

### **Question pools**

All of the VECs are responsible for maintaining the question pools from which all amateur license examination questions must be taken.

## **Volunteer Examiners (VEs):**

### **Definition/Requirements/Accreditation**

An accredited Volunteer Examiner is an amateur operator who is approved by a VEC to administer amateur operator license examinations.

A VE Team is a group of at least three VEs who administer examinations for an amateur operator license.

### **Reimbursement for expenses**

Preparing, processing, administering and coordinating an examination for an amateur radio license are the types of out-of-pocket expenses for which the FCC rules authorize a VE and VEC to accept reimbursement.

Actual out-of-pocket expenses may be reimbursed to the VE team and VEC accept for preparing, processing, administering and coordinating an examination.

### **VE conduct**

Revocation of the VE's amateur station license grant and the suspension of the VE's amateur operator license grant may be the penalty for a VE who fraudulently administers or certifies an examination.

### **Preparing an examination/Examination elements**

An Extra class VE or a qualified supplier who selects questions from the appropriate VEC question pool may prepare an Element 4 amateur operator license examination.

### **Definition of code and written elements**

The purpose of an amateur operator telegraphy examination is it proves that the examinee has the ability to send correctly by hand and to receive correctly by ear, texts in the International Morse Code.

### **Examination requirements**

The questions that are listed in the VEC-maintained question pool must be used in all written US amateur license examinations.

The purpose of an Element 4 examination is it proves the examinee has the qualifications necessary to perform properly the duties of an Amateur Extra Class operator.

### **Examination procedure/ Examination administration**

All administering VEs on the VE team must be present and observing the examinees throughout the entire examination.

The administering VEs are responsible for the proper conduct and necessary supervision during an amateur operator license examination session.

A VE should immediately terminate the candidate's examination if a candidate fails to comply with the examiner's instructions during an amateur operator license examination.

A VE team must a special procedure that accommodates the disability for an examinee with a physical disability.

A VE may not administer an examination to the VE's close relatives as listed in the FCC rules.

The VE team must collect and grade your test papers immediately when you have finished the examination.

Three VEs must certify that the examinee is qualified for the license grant and that they have complied with the VE requirements if an examinee scores a passing grade on all examination elements needed for an upgrade or new license.

The VE team must return the application document to the examinee and inform the examinee of the grade if the examinee does not score a passing grade on the examination.

The consequences of failing to appear for re-administration of an examination when so directed by the FCC is the licensee's license will be cancelled and a new license will be issued that is consistent with examination elements not invalidated.

#### **Certification of external RF power amplifiers and external RF power amplifier kits**

If an external RF amplifier is listed on the FCC database as certificated for use in the amateur service it means that particular RF amplifier model may be marketed for use in the amateur service.

An equipment dealer may sell an external RF power amplifier capable of operation below 144 MHz if it has not been granted FCC certification if it was purchased in used condition from an amateur operator and is sold to another amateur operator for use at that operator's station.

#### **Line A**

Line A is a line roughly parallel to, and south of, the US-Canadian border

Amateur stations may not transmit in the 420-430 MHz frequency segment if they are located north of Line A.

#### **National Radio Quiet Zone**

The National Radio Quiet Zone is an Area in Maryland, West Virginia and Virginia surrounding the National Radio Astronomy Observatory.

A Beacon station must not be established in the National Radio Quiet Zone before the licensee gives written notification to the National Radio Astronomy Observatory.

### **Business communications**

Under no circumstances may the control operator of a repeater accept payment for providing communication services to another party.

An amateur station may send a message to a business when neither the amateur nor his or her employer has a pecuniary interest in the communications.

Communications transmitted for hire or material compensation, except as otherwise provided in the rules are types of amateur operator-to-amateur operator communication that are prohibited.

### **Definition and operation of spread spectrum**

Spread spectrum is the term for emissions using bandwidth-expansion modulation.

FCC-licensed amateur stations may use spread spectrum (SS) emissions to communicate under the following conditions:

- When the other station is in an area regulated by the FCC
- When the other station is in a country permitting SS communications
- When the transmission is not used to obscure the meaning of any communication
- (All of these choices are correct)

Under any circumstance, 100 W is the maximum transmitter power for an amateur station transmitting emission type SS communications.

### **Auxiliary station operation**

The following are uses for an auxiliary station:

- To provide a point-to-point communications uplink between a control point and its associated remotely controlled station
- To provide a point-to-point communications downlink between a remotely controlled station and its control point
- To provide a point-to-point control link between a control point and its associated remotely controlled station
- All of these choices are correct

## **SUBELEMENT E2 -- OPERATING PROCEDURES [5 Exam Questions - 5 Groups]**

### **Amateur Satellites:**

#### **Orbital mechanics**

The direction of an ascending pass for an amateur satellite is from south to north.

The direction of a descending pass for an amateur satellite is from north to south.

The period of an amateur satellite is the amount of time it takes for a satellite to complete one orbit.

#### **Frequencies available for satellite operation**

The receiving and retransmitting frequency bands used for Mode V/H in amateur satellite operations is satellite receiving on 144 to 148 MHz and retransmitting on Amateur bands in the range of 21 to 30 MHz.

The receiving and retransmitting frequency bands used for Mode U/V in amateur satellite operations is satellite receiving on 435 to 438 MHz and retransmitting on 144 to 148 MHz.

The receiving and retransmitting frequency bands used for Mode V/U in amateur satellite operations is satellite receiving on 144 to 148 MHz and retransmitting on 435 to 438 MHz.

The receiving and retransmitting frequency bands used for Mode L/U in amateur satellite operations is satellite receiving on 1.26 to 1.27 GHz and retransmitting on 435 to 438 MHz.

#### **Satellite hardware**

A linear transponder is a device that receives and retransmits signals of any mode in a certain passband.

#### **Satellite operations**

The Doppler Effect is the name of the effect that causes the downlink frequency of a satellite to vary by several kHz during a low-earth orbit.

Because the satellite is rotating, the received signal from an amateur satellite exhibit may have a fairly rapid pulsed fading effect.

A circularly polarized antenna can be used to minimize the effects of spin modulation and Faraday rotation.

The location of a satellite at a given time may be predicted by means of the Keplerian elements for the specified satellite.

## **Television:**

### **Fast scan television (FSTV) standards**

A new frame is transmitted 30 times per second in a fast-scan television system.

A fast-scan television frame has 525 horizontal lines.

The interlace scanning pattern generated in a fast-scan television system is generated by scanning odd numbered lines in one field and even numbered ones in the next.

Blanking in a video signal is the turning off the scanning beam while it is traveling from right to left and from bottom to top.

The bandwidth of a vestigial sideband AM fast-scan television transmission is 6 MHz.

The standard video level, in percent PEV, for black in amateur fast scan television is 70%.

The standard video level, in percent PEV, for blanking in amateur fast scan television is 75%.

Amplitude modulation of the video carrier is NOT a common method of transmitting accompanying audio with amateur fast-scan television.

The standard video level, in percent PEV, for white in an amateur fast-scan television transmission is 12.5%.

### **Slow scan television (SSTV) standards**

Still pictures are sent by slow-scan television transmissions.

Commonly, 128 or 256 lines are used in each frame on an amateur slow-scan color television picture.

The audio frequency for black in an amateur slow-scan television picture is 1500 Hz.

The audio frequency for white in an amateur slow-scan television picture is 2300 Hz.

The approximate bandwidth of a slow-scan TV signal is 2 kHz.

Immunity from fading due to limiting is NOT a characteristic of FMTV (Frequency-Modulated Amateur Television) as compared to vestigial sideband AM television.

### **Facsimile (fax) communications**

Facsimile is the transmission of printed pictures for permanent display on paper.

The modern standard scan rate for a fax image transmitted by an amateur station is 240 lines per minute.

The approximate transmission time per frame for a fax picture transmitted by an amateur station at 240 lpm is 3.3 minutes.

Facsimile is used to transmit high-quality still images by radio.

Fax transmissions are allowed in phone band segments if their bandwidth is no greater than that of a voice signal of the same modulation type.

### **Contest and DX operating**

When operating during a contest, always listen before transmitting, be courteous and do not cause harmful interference to other communications.

One of the main purposes for holding on-the-air operating contests is to enhance the communicating and operating skills of amateur operators in readiness for an emergency.

Typical of operations during an international amateur DX contest, some DX operators use split frequency operations (transmitting on a frequency different from the receiving frequency).

If a DX station asks for your grid square locator, your reply should be your geographic Maidenhead grid location (e.g., FN31AA) based on your current latitude and longitude.

A Maidenhead gridsquare refers to a two-degree longitude by one-degree latitude square, as part of a world wide numbering system.

During a VHF/UHF contest, you would expect to find the highest level of contest activity in the weak signal segment of the band, with most of the activity near the calling frequency.

If you are in the US calling a station in Texas on a frequency of 1832 kHz and a station replies that you are in the window, it means you are transmitting in a frequency segment that is reserved for international DX contacts by gentlemen's agreement.

While participating in an HF contest, you should attempt to contact a station calling CQ and stating that he is listening on another specific frequency by sending your full call sign on the listening frequency specified.

When operating SSB in a VHF contest, you should attempt to contact a station calling CQ while a pileup of other stations are also trying to contact the same station by sending your full call sign after the distant station transmits QRZ.

### **Spread-spectrum transmissions**

Received spread-spectrum signals are so resistant to interference because signals not using the spectrum-spreading algorithm are suppressed in the Receiver.

The spread-spectrum technique of frequency hopping (FH) works because the frequency of the transmitted signal is changed very rapidly according to a particular sequence also used by the receiving station.

## **Selecting your operating frequency**

In North America during low sunspot activity, signals from Europe become weak and fluttery across an entire HF band two to three hours after sunset.

Switching to a lower frequency HF band might help to contact other European DX stations because the MUF has decreased.

## **Operating VHF / UHF digital modes:**

### **Packet clusters/ Digital bulletin boards**

When CMD: is displayed on the video monitor of a packet station it means the TNC is in command mode, ready to receive instructions from the keyboard.

A Packet Cluster Bulletin Board is a packet bulletin board devoted primarily to serving a special interest group.

The purpose of a digital store and forward on an Amateur satellite is to store messages in an amateur satellite for later download by other stations.

Store and forward is a technique normally used by low-earth orbiting digital satellites to relay messages around the world.

In comparing HF and 2-meter packet Operations, it is NOT true that HF packet is limited to Amateur Extra class amateur licensees; 2-meter packet is open to all but Novice Class amateur licensees.

Under clear communications conditions, 300-baud packet digital communications mode has the fastest data throughput.

### **Automatic Position Reporting System (APRS)**

The common 2-meter APRS frequency is 144.39 MHz.

APRS uses AX.25 digital protocol.

Unnumbered Information frames are the type of packet frames used to transmit APRS beacon data.

An APRS station with a GPS unit can automatically transmit information to show the station's position along the course route to help support a public service communications activity, such as a walk-a-thon.

The following data sources are needed to accurately transmit your geographical location over the APRS network:

- The NMEA-0183 formatted data from a Global Positioning System (GPS) satellite receiver
- The latitude and longitude of your location, preferably in degrees, minutes and seconds, entered into the APRS computer software
- The NMEA-0183 formatted data from a LORAN navigation system
- (All of these choices are correct)

### **Operating HF digital modes**

FSK (frequency-shift keying) of an RF carrier is the most common method of transmitting data emissions below 30 MHz.

The letters FEC mean Forward Error Correction as they relate to AMTOR operation.

Forward Error Correction is implemented by transmitting extra data that may be used to detect and correct transmission errors.

If an oscilloscope is connected to a TNC or terminal unit and is displaying two crossed ellipses, one of which suddenly disappears, the observed signal would indicate the phenomenon known as selective fading has occurred.

AMTEX is the name for a bulletin transmission system that includes a special header to allow receiving stations to determine if the bulletin has been previously received.

The most common data rate used for HF packet communications is 300 bauds.

The typical bandwidth of a properly modulated MFSK16 signal is 316 Hz.

PACTOR is an HF digital mode that can be used to transfer binary files. The Baudot code is the International Telegraph Alphabet Number 2 (ITA2) which uses five data bits.

Of the digital communications modes, PSK31 has the narrowest bandwidth.

## **SUBELEMENT E3 -- RADIO WAVE PROPAGATION [3 Exam Questions - 3 Groups]**

### **Earth-Moon-Earth (EME or moonbounce) communications**

The maximum separation between two stations communicating by moonbounce is any distance as long as the stations have a mutual lunar window.

A fluttery irregular fading characterizes libration fading of an earth-moon-earth signal.

When scheduling EME contacts, the least path loss is when the moon is at perigee.

Receiving system equipment with very low noise figures is desirable for EME communications.

Two-minute transmit and receive time sequences are normally used on 144 MHz when attempting an earth-moon-earth contact where one station transmits for a full two minutes and then receives for the following two minutes.

Two and one half minute transmit and receive time sequences are normally used on 432 MHz when attempting an EME contact where one station transmits for a full 2.5 minutes and then receives for the following 2.5 minutes.

You would normally tune to the frequency range, 144.000 - 144.100 MHz, to find EME stations in the 2-meter band.

You would normally tune to the frequency range, 432.000 - 432.100 MHz, to find EME stations in the 70-cm band.

### **Meteor scatter**

When a meteor strikes the earth's atmosphere, a cylindrical region of free electrons is formed at the E layer of the ionosphere.

The range of frequencies, 28 - 148 MHz, is well suited for meteor-scatter communications.

A 15-second transmit and receive time sequence is normally used on 144 MHz when attempting a meteor-scatter contact where one station transmits for 15 seconds and then receives for the following 15 seconds.

### **Transequatorial**

Transequatorial propagation is propagation between two points at approximately the same distance north and south of the magnetic equator.

The approximate maximum range for signals using transequatorial propagation is 5000 miles.

The best time of day for transequatorial propagation is the afternoon or early evening.

### **Long path**

On the 160 to 10 meters amateur bands long-path propagation can provide signal enhancement.

Long-path propagation is probably occurring if an HF beam antenna must be pointed in a direction 180 degrees away from a station to receive the strongest signals.

The 20 meter amateur band consistently yields long-path enhancement using a modest antenna of relatively high gain.

The typical reason for hearing an echo on the received signal of a station in Europe while directing your HF antenna toward the station is there are two signals being received, one from the most direct path and one from long-path propagation.

### **Gray line**

Gray-line propagation is probably occurring if radio signals travel along the terminator between daylight and darkness.

Gray-line propagation is most prevalent at twilight, at sunrise and sunset.

The cause of gray-line propagation is at twilight solar absorption drops greatly while atmospheric ionization is not weakened enough to reduce the MUF.

Contacts up to 8,000 to 10,000 miles on three or four HF bands are possible during gray-line propagation.

### **Auroral propagation**

CW signals can have a fluttery tone due to auroral activity.

The cause of auroral activity is the emission of charged particles from the sun.

Auroral activity occurs at E-region height in the ionosphere.

CW is the best emission mode for auroral propagation.

In the northern hemisphere, a directional antenna should be pointed north to take maximum advantage of auroral propagation.

### **Selective fading**

Selective fading is caused by phase differences between radio-wave components of the same transmission, as experienced at the receiving station.

Selective fading is more pronounced at wide bandwidths.

### **Radio-path horizon**

VHF/UHF radio-path horizon distance exceeds the geometric horizon by approximately 15% of the distance.

### **Take-off angle over flat or sloping terrain**

For a 3-element beam antenna with horizontally mounted elements, the main lobe takeoff angle decreases with increasing height above flat ground.

The name of the high-angle wave in HF propagation that travels for some distance within the F2 region is the Pedersen ray.

For a 3-element beam antenna with horizontally mounted elements, the main lobe takeoff angle decreases as the slope gets steeper and varies with the downward slope of the ground (moving away from the antenna).

#### **Earth effects on propagation**

Tropospheric ducting effect is usually responsible for propagating a VHF signal over 500 miles.

As the frequency of a signal is increased, ground wave propagation decreases.

Ground-wave propagation has vertical polarization.

The radio-path horizon distance exceeds the geometric horizon because radio waves may be bent.

**SUBELEMENT E4 -- AMATEUR RADIO PRACTICES [5 Exam Questions -- 5 Groups]**

**Test equipment:**

**Spectrum analyzers (interpreting spectrum analyzer displays & transmitter output spectrum)**

A spectrum analyzer differs from a conventional time-domain oscilloscope in that a spectrum analyzer displays signals in the frequency domain; an oscilloscope displays signals in the time domain.

The horizontal axis of a spectrum analyzer displays the Frequency parameter.

The vertical axis of a spectrum analyzer displays the Amplitude parameter.

A spectrum analyzer is used to display spurious signals from a radio Transmitter.

A spectrum analyzer is used to display intermodulation distortion products in an SSB transmission.

The speed at which a transceiver switches from transmit to receive when being used for packet radio is NOT something that could be determined with a spectrum analyzer.

An advantage of using a spectrum analyzer to observe the output from a VHF transmitter is that it displays all frequency components of the transmitted signal.

When connecting a spectrum analyzer to a transmitter output you should attenuate the transmitter output going to the spectrum analyzer.

**Logic probes (indications of high and low states in digital circuits & indications of pulse conditions in digital circuits)**

An advantage a logic probe has over a voltmeter for monitoring the status of a logic circuit is that it is smaller and shows a simplified readout.

A logic probe is used to directly indicate high and low digital voltage states.

A logic probe can indicate the high and low logic states about a digital logic circuit.

A logic probe can be used to indicate pulse conditions in a digital logic circuit.

**Frequency measurement devices (i.e., frequency counter, oscilloscope Lissajous figures, dip meter)**

A frequency standard is a device used to produce a highly accurate reference frequency.

The frequency response of an oscilloscope can be improved by increasing the horizontal sweep rate and the vertical amplifier frequency response.

The accuracy of a frequency counter may be improved by increasing the accuracy of the time base.

If a frequency counter with a specified accuracy of  $\pm 0.1$  ppm reads 146,520,000 Hz, 14.652 Hz is the most the actual frequency being measured could differ from the reading.

If a frequency counter with a specified accuracy of  $\pm 1.0$  ppm reads 146,520,000 Hz, 146.52 Hz is the most the actual frequency being measured could differ from the reading.

If a frequency counter with a specified accuracy of  $\pm 10$  ppm reads 146,520,000 Hz, 1465.20 Hz is the most the actual frequency being measured could differ from the reading.

If a frequency counter with a specified accuracy of  $\pm 0.1$  ppm reads 432,100,000 Hz, 43.21 Hz is the most the actual frequency being measured could differ from the reading.

If a frequency counter with a specified accuracy of  $\pm 1.0$  ppm reads 432,100,000 Hz, 432.1 Hz is the most the actual frequency being measured could differ from the reading.

If a frequency counter with a specified accuracy of  $\pm 10$  ppm reads 432,100,000 Hz, 4321 Hz is the most the actual frequency being measured could differ from the reading.

If a 100 Hz signal is fed to the horizontal input of an oscilloscope and a 150 Hz signal is fed to the vertical input, a Lissajous figure will be displayed on the screen appearing like a looping pattern with 3 loops horizontally and 2 loops vertically

A dip-meter is a device consisting of a variable frequency LC oscillator and an indicator showing the metered feedback current.

A dip-meter gives an indication of the resonant frequency of a nearby circuit.

A dip-meter functions when the power coupled from an oscillator causes a decrease in metered current.

The two ways a dip-meter could be used in an amateur station is to measure resonant frequency of antenna traps and to measure a tuned circuit resonant frequency.

For best accuracy, a dip-meter should be coupled as loosely as possible with the LC circuit being checked.

Less accurate reading results happen in a dip-meter when it is too tightly coupled with a tuned circuit being checked.

#### **Meter performance limitations**

Calibration, mechanical tolerance and coil impedance are factors that limit the accuracy, frequency response and stability of a D'Arsonval-type meter.

### **Oscilloscope performance limitations**

Accuracy and linearity of the time base and the linearity and bandwidth of the deflection amplifiers are factors that limit the accuracy, frequency response and stability of an oscilloscope.

### **Frequency counter performance limitations**

Time base accuracy, speed of the logic and time base stability are factors that limit the accuracy, frequency response and stability of a frequency counter.

### **Receiver performance characteristics (i.e., phase noise, desensitization, capture effect, intercept point, noise floor, dynamic range {blocking and IMD}, Image rejection, MDS, Signal-to-noise-ratio)**

The effect of excessive phase noise in the local oscillator section of a receiver is it allows strong signals on nearby frequencies to interfere with reception of weak signals.

Desensitization is the term for the reduction in receiver sensitivity caused by a strong signal near the received frequency.

Strong adjacent-channel signals can cause receiver desensitization.

One way receiver desensitization can be reduced is improve the shielding between the receiver and the transmitter causing the problem.

The FM capture effect occurs when the strongest signal received is the only demodulated signal.

Capture effect is the term for the blocking of one FM phone signal by another, stronger FM phone signal.

The noise floor of a receiver is the weakest signal that can be detected above the receiver internal noise.

The blocking dynamic range for a receiver is 119 dB when it has an 8-dB noise figure and an IF bandwidth of 500 Hz when the blocking level (1-dB compression point) is -20 dBm.

The dynamic range of a communications receiver is the ratio between the minimum discernible signal and the largest tolerable signal without causing audible distortion products.

Cross modulation of the desired signal and desensitization from strong adjacent signals are caused by poor dynamic range in a communications receiver.

If you measured the MDS of a receiver, you would be measuring the minimum discernible signal (MDS), or the weakest signal that the receiver can detect.

Two factors that determine the sensitivity of a receiver are Bandwidth and noise figure.

The noise floor of the receiver is the limiting condition for sensitivity in a communications receiver.

Selectivity can be achieved in the front-end circuitry of a communications receiver by using a preselector.

Selectivity of 300 Hz is desirable in the IF circuitry of an amateur RTTY receiver.

### **Intermodulation and cross-modulation interference**

Intermodulation interference between two repeater transmitters usually occurs when they are in close proximity and the signals mix in one or both of their final amplifiers.

Intermodulation interference between two repeater transmitters in close proximity often can be reduced or eliminated by installing a terminated circulator or ferrite isolator in the feed line to the transmitter and duplexer.

Nonlinear circuits or devices cause intermodulation in an electronic circuit.

If a receiver tuned to 146.70 MHz receives an intermodulation-product signal whenever a nearby transmitter transmits on 146.52 MHz, the two most likely frequencies for the other interfering signal are 146.34 MHz and 146.61 MHz.

If the signals of two transmitters mix together in one or both of their final amplifiers and unwanted signals at the sum and difference frequencies of the original signals are generated, this is called Intermodulation interference.

Cross-modulation interference is modulation from an unwanted signal is heard in addition to the desired signal.

Selectivity of 2.4 kHz is desirable in the IF circuitry of a single-sideband phone receiver.

An undesirable effect of using too wide a filter bandwidth in the IF section of a receiver is undesired signals will reach the audio stage.

The filter bandwidth, of a receiver IF section, should be slightly greater than the received-signal bandwidth.

Selectivity of 15 kHz is desirable in the IF section of an FM phone receiver.

In a receiver, if the third-order intermodulation products have a power of -70 dBm when using two test tones at -30 dBm, the third-order intercept point is -10 dBm.

In a receiver, if the second-order intermodulation products have a power of -70 dBm when using two test tones at -30 dBm, the second-order intercept point is +10 dBm.

### **Noise suppression:**

#### **Vehicular system noise**

Ignition noise is one of the most significant problems associated with reception in HF transceivers.

The proper procedure for suppressing electrical noise in a mobile transceiver is to follow the vehicle manufacturer's recommended procedures.

Ferrite beads should be installed in the primary and secondary ignition leads to suppress ignition noise in a mobile transceiver.

Alternator whine can be minimized by connecting the radio's power leads to the battery by the shortest possible path.

Conducted and radiated noise caused by an automobile alternator can be suppressed by connecting the radio's power leads directly to the battery and by installing coaxial capacitors in the alternator leads.

#### **Electronic motor noise**

Noise from an electric motor can be suppressed by installing a brute-force, AC-line filter in series with the motor leads.

#### **Static**

Thunderstorms are a major cause of atmospheric static.

#### **Line noise**

It can be determined if line-noise interference is being generated within your home by turning off the AC power line main circuit breaker and listening on a battery-operated radio.

A common-mode signal at the frequency of the radio transmitter is picked up by electrical wiring near a radio transmitter.

An FM receiver with a directional antenna would be least useful in locating power line noise.

#### **Component mounting techniques (i.e., surface, dead bug (raised), circuit board**

Surface mounting circuit construction technique uses leadless components mounted between circuit board pads.

#### **Direction finding: techniques and equipment**

The main drawback of a wire-loop antenna for direction finding is it has a bidirectional pattern broadside to the loop.

The pattern desirable for a direction-finding antenna is one with good front-to-back and front-to-side ratio.

The triangulation method of direction finding is where Beam antenna headings from several receiving stations are used to plot the signal source on a map.

An RF attenuator is desirable in a receiver used for direction finding because it prevents receiver overload from extremely strong signals.

A sense antenna is a vertical antenna added to a loop antenna to produce a cardioid reception pattern.

A loop antenna is several turns of wire wound in the shape of a large open coil.

The output voltage of a loop antenna can be increased by increasing either the number of wire turns in the loop or the area of the loop structure.

An antenna with a cardioid pattern is desirable for a direction-finding system because the deep null of the cardioid pattern can pinpoint the direction of the desired station.

Varied terrain can cause errors in direction finding.

### **Fox hunting**

The amateur station activity known as fox hunting is where operators attempt to locate a hidden transmitter by using receivers and direction-finding techniques.

**SUBELEMENT E5 -- ELECTRICAL PRINCIPLES [9 Exam Questions -- 9 Groups]**

**Characteristics of resonant circuits:**

**Resonance**

Resonance in an electrical circuit is the frequency at which capacitive reactance equals inductive reactance.

Resonance occurs in an electrical circuit when the inductive and capacitive reactances are equal.

When the inductive reactance of an electrical circuit equals its capacitive reactance, the condition is called Resonance.

The voltage and current are in phase between the current through a resonant circuit and the voltage across the circuit.

**Series resonance (capacitor and inductor to resonate at a specific frequency)**

Resonance can cause the voltage across reactances in series to be larger than the voltage applied to them.

The magnitude of the impedance of a series R-L-C circuit at resonance is an approximately equal to circuit resistance.

The magnitude of the current is at a maximum at the input of a series R-L-C circuit.

If R is 47 ohms, L is 50 microhenrys and C is 40 picofarads, the resonant frequency of the series RLC circuit is 3.56 MHz.

If R is 47 ohms, L is 40 microhenrys and C is 200 picofarads, the resonant frequency of the series RLC circuit is 1.78 MHz.

If R is 47 ohms, L is 50 microhenrys and C is 10 picofarads, the resonant frequency of the series RLC circuit is 7.12 MHz.

If R is 47 ohms, L is 25 microhenrys and C is 10 picofarads, the resonant frequency of the series RLC circuit is 10.1 MHz.

If R is 47 ohms, L is 3 microhenrys and C is 40 picofarads, the resonant frequency of the series RLC circuit is 14.5 MHz.

If R is 47 ohms, L is 4 microhenrys and C is 20 picofarads, the resonant frequency of the series RLC circuit is 17.8 MHz.

If R is 47 ohms, L is 8 microhenrys and C is 7 picofarads, the resonant frequency of a series RLC circuit is 21.3 MHz.

If R is 47 ohms, L is 3 microhenrys and C is 15 picofarads, the resonant frequency of a series RLC circuit is 23.7 MHz.

### **Parallel resonance (capacitor and inductor to resonate at a specific frequency)**

The magnitude of the impedance of a circuit with a resistor, an inductor and a capacitor all in parallel, at resonance is approximately equal to circuit resistance.

The magnitude of the circulating current is at a maximum within the components of a parallel L-C circuit at resonance.

The magnitude of the current is at a minimum at the input of a parallel R-L-C circuit at resonance.

The voltage and current are in phase between the current into (or out of) a parallel resonant circuit and the voltage across the circuit.

### **Half-power bandwidth**

The half-power bandwidth of a parallel resonant circuit that has a resonant frequency of 1.8 MHz and a Q of 95 is 18.9 kHz.

The half-power bandwidth of a parallel resonant circuit that has a resonant frequency of 7.1 MHz and a Q of 150 is 47.3 kHz.

The half-power bandwidth of a parallel resonant circuit that has a resonant frequency of 14.25 MHz and a Q of 150 is 95 kHz.

The half-power bandwidth of a parallel resonant circuit that has a resonant frequency of 21.15 MHz and a Q of 95 is 222.6 kHz.

The half-power bandwidth of a parallel resonant circuit that has a resonant frequency of 3.7 MHz and a Q of 118 is 31.4 kHz.

The half-power bandwidth of a parallel resonant circuit that has a resonant frequency of 14.25 MHz and a Q of 187 is 76.2 kHz.

### **Exponential charge/discharge curves (time constants):**

#### **Definition**

The term for the time required for the capacitor in an RC circuit to be charged to 63.2% of the supply voltage is one time constant.

The term for the time required for the current in an RL circuit to build up to 63.2% of the maximum value is one time constant.

The term for the time it takes for a charged capacitor in an RC circuit to discharge to 36.8% of its initial value of stored charge is one time constant.

#### **Time constants in RL and RC circuits**

The capacitor in an RC circuit is charged to 86.5% of the supply voltage after two time constants.

The capacitor in an RC circuit is discharged to 13.5% of the starting voltage after two time constants.

The time constant of a circuit having two 100-microfarad capacitors and two 470-kilohm resistors all in series is 47 seconds.

The time constant of a circuit having two 220-microfarad capacitors and two 1-megohm resistors all in parallel is 220 seconds.

The time constant of a circuit having a 220-microfarad capacitor in series with a 470-kilohm resistor is 103 seconds.

It takes 0.02 seconds for an initial charge of 20 V DC to decrease to 7.36 V DC in a 0.01-microfarad capacitor when a 2-megohm resistor is connected across it.

It takes 0.08 seconds for an initial charge of 20 V DC to decrease to 0.37 V DC in a 0.01-microfarad capacitor when a 2-megohm resistor is connected across it.

It takes 450 seconds for an initial charge of 800 V DC to decrease to 294 V DC in a 450-microfarad capacitor when a 1-megohm resistor is connected across it.

### **Impedance diagrams:**

#### **Basic principles of Smith charts**

A Smith chart can be used to calculate impedance along transmission lines.

The coordinate system used in a Smith chart is Resistance circles and reactance arcs.

Impedance and SWR values in transmission lines calculations can be performed using a Smith chart.

Resistance and reactance are the two families of circles that make up a Smith chart.

A Smith chart is shown in Figure E5-1.

**Figure E5-1**

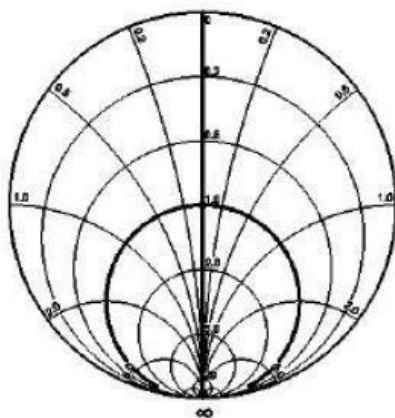

On the Smith chart shown in Figure E5-1, reactance axis is the name for the large outer circle bounding the coordinate portion of the chart.

On the Smith chart shown in Figure E5-1, the resistance axis is the only straight line shown.

Reassigning impedance values with regard to the prime center is the process of normalizing with regard to a Smith chart.

Standing-wave ratio circles are the third family of circles, which are added to a Smith chart during the process of solving problems.

The curved lines on a Smith chart are portions of reactance circles.

The wavelength scales on a Smith chart are calibrated in portions of transmission line electrical wavelength.

### Impedance of RLC networks at specified frequencies

In rectangular coordinates, the impedance of a network comprised of a 10-microhenry inductor in series with a 40-ohm resistor at 500 MHz is  $40 + j31,400$ .

In polar coordinates, the impedance of a network comprised of a 100-picofarad capacitor in parallel with a 4,000-ohm resistor at 500 kHz is 2490 ohms,  $-51.5$  degrees.

### PC based impedance analysis (including Smith Charts)

Point 8 on Figure E5-2 best represents the impedance of a series circuit consisting of a 300-ohm resistor, a 0.64-microhenry inductor and an 85-picofarad capacitor at 24.900 MHz.

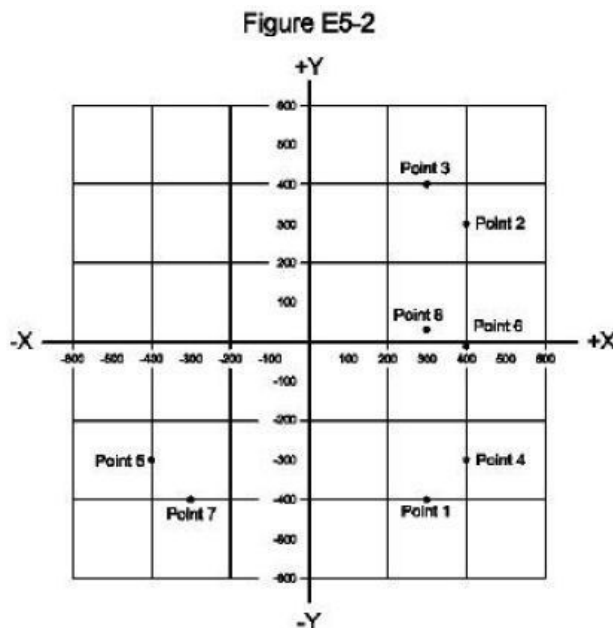

### **Phase angle between voltage and current**

The phase angle between the voltage across and the current through a series R-L-C circuit if XC is 25 ohms, R is 100 ohms, and XL is 100 ohms is 36.9 degrees with the voltage leading the current.

The phase angle between the voltage across and the current through a series R-L-C circuit if XC is 500 ohms, R is 1 kilohm, and XL is 250 ohms is 14.0 degrees with the voltage lagging the current.

The phase angle between the voltage across and the current through a series R-L-C circuit if XC is 50 ohms, R is 100 ohms, and XL is 25 ohms is 14 degrees with the voltage lagging the current.

The phase angle between the voltage across and the current through a series R-L-C circuit if XC is 100 ohms, R is 100 ohms, and XL is 75 ohms is 14 degrees with the voltage lagging the current.

The phase angle between the voltage across and the current through a series R-L-C circuit if XC is 50 ohms, R is 100 ohms, and XL is 75 ohms is 14 degrees with the voltage leading the current.

The relationship between the current through and the voltage across a Capacitor is current leads voltage by 90 degrees.

The relationship between the current through an inductor and the voltage across an inductor is voltage leads current by 90 degrees.

### **Impedances and phase angles of series and parallel circuits**

The phase angle between the voltage across and the current through a series RLC circuit if XC is 25 ohms, R is 100 ohms, and XL is 50 ohms is 14 degrees with the voltage leading the current.

The phase angle between the voltage across and the current through a series RLC circuit if XC is 75 ohms, R is 100 ohms, and XL is 100 ohms is 14 degrees with the voltage leading the current.

The phase angle between the voltage across and the current through a series RLC circuit if XC is 75 ohms, R is 100 ohms, and XL is 50 ohms is 14 degrees with the voltage lagging the current.

The phase angle between the voltage across and the current through a series RLC circuit if XC is 250 ohms, R is 1 kilohm, and XL is 500 ohms is 14.04 degrees with the voltage leading the current.

### **Algebraic operations using complex numbers:**

#### **Polar coordinates (magnitude and angle)**

You would plot the impedance of a circuit using the polar coordinate system to give a visual representation of the phase angle.

The Polar coordinate system can be used to display the phase angle of a circuit containing resistance, inductive and/or capacitive reactance.

In polar coordinates, the impedance of a circuit of 100 -j100 ohms impedance is 141 ohms, / -45 degrees.

In polar coordinates, the impedance of a circuit that has an admittance of 7.09 millisiemens at 45 degrees is 141 ohms, / -45 degrees.

In polar coordinates, the impedance of a network comprised of a 100-ohm-reactance inductor in series with a 100-ohm resistor is 141 ohms, / 45 degrees.

In polar coordinates, the impedance of a network comprised of a 100-ohm-reactance inductor, a 100-ohm-reactance capacitor, and a 100-ohm resistor all connected in series is 100 ohms, / 0 degrees.

In polar coordinates, the impedance of a network comprised of a 300-ohm-reactance capacitor, a 600-ohm-reactance inductor, and a 400-ohm resistor, all connected in series is 500 ohms, / 37 degrees.

In polar coordinates, the impedance of a network comprised of a 400-ohm-reactance capacitor in series with a 300-ohm resistor is 500 ohms, / -53.1 degrees.

In polar coordinates, the impedance of a network comprised of a 400-ohm-reactance inductor in parallel with a 300-ohm resistor is 240 ohms, / 36.9 degrees.

In polar coordinates, the impedance of a network comprised of a 100-ohm-reactance capacitor in series with a 100-ohm resistor is 141 ohms, / -45 degrees.

In polar coordinates, the impedance of a network comprised of a 100-ohm-reactance capacitor in parallel with a 100-ohm resistor is 71 ohms, / -45 degrees.

In polar coordinates, the impedance of a network comprised of a 300-ohm-reactance inductor in series with a 400-ohm resistor is 500 ohms, / 37 degrees.

In polar coordinates, the impedance of a series circuit consisting of a resistance of 4 ohms, an inductive reactance of 4 ohms, and a capacitive reactance of 1 ohm is 5 ohms, / 37 degrees.

### **Rectangular coordinates (real and imaginary parts)**

When using rectangular coordinates to graph the impedance of a circuit, the horizontal axis represents the voltage or current associated with the resistive component.

When using rectangular coordinates to graph the impedance of a circuit, the vertical axis represents the voltage or current associated with the reactive component.

The two numbers that are used to define a point on a graph using rectangular coordinates represent the coordinate values along the horizontal and vertical axes.

If you plot the impedance of a circuit using the rectangular coordinate system and find the impedance point falls on the right side of the graph on the horizontal line, you know that the circuit is equivalent to a pure resistance.

The Rectangular coordinate system can be used to display the resistive, inductive, and/or capacitive reactance components of impedance.

In rectangular coordinates, the impedance of a circuit that has an admittance of 5 millisiemens at -30 degrees is  $173 + j100$  ohms.

In rectangular coordinates, the admittance of a circuit that has an impedance of 240 ohms at 36.9 degrees is  $3.33 \times 10^{-3} - j2.50 \times 10^{-3}$  siemens.

Point 1 on Figure E5-2 best represents the impedance of a series circuit consisting of a 300 ohm resistor and a 19 picofarad capacitor at 21.200 MHz.

Point 3 in Figure E5-2 best represents the impedance of a series circuit consisting of a 300 ohm resistor and an 18 microhenry inductor at 3.505 MHz.

Point 4 on Figure E5-2 best represents the impedance of a series circuit consisting of a 400 ohm resistor and a 38 picofarad capacitor at 14 MHz.

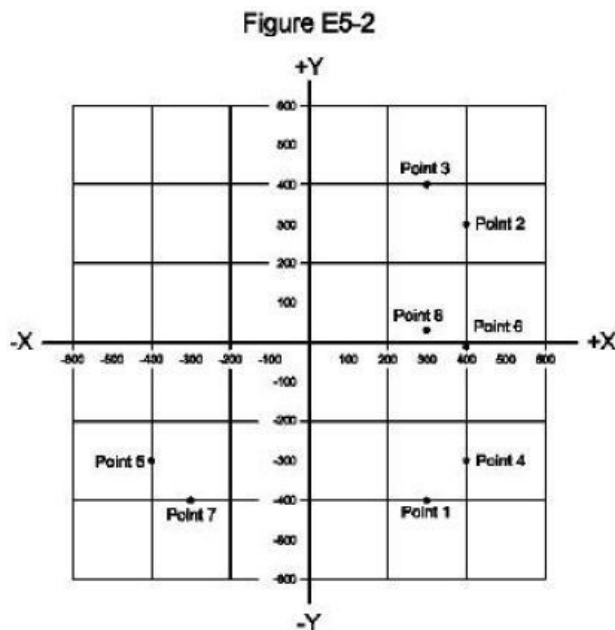

### **Skin effect**

As frequency increases, RF current flows in a thinner layer of the conductor, closer to the surface is the result of skin effect.

Skin effect causes most of an RF current to flow along the surface of a conductor.

Almost all RF current flow in a conductor flows along the surface of the conductor.

Most of an RF current flows near the surface of a conductor because of skin effect.

The resistance of a conductor is different for RF currents than for direct currents because of skin effect.

### **Electrostatic and electromagnetic fields**

A capacitor is used to store electrical energy in an electrostatic field.

The Joule is the unit used to measure electrical energy stored in an electrostatic field.

A magnetic field is the space through which a magnetic force acts.

The direction of the magnetic field is oriented about a conductor in relation to the direction of electron flow determined by the left-hand rule.

The amount of current determines the strength of a magnetic field around a conductor.

Potential energy is the term for energy that is stored in an electromagnetic or electrostatic field.

### **Circuit Q**

A resistor is often included in a parallel resonant circuit to decrease the Q and increase the bandwidth.

The Q of a parallel R-L-C circuit if the resonant frequency is 14.128 MHz, L is 2.7 microhenrys and R is 18 kilohms is 75.1.

The Q of a parallel R-L-C circuit if the resonant frequency is 4.468 MHz, L is 47 microhenrys and R is 180 ohms is 0.136.

The Q of a parallel R-L-C circuit if the resonant frequency is 7.125 MHz, L is 8.2 microhenrys and R is 1 kilohm is 2.72.

The Q of a parallel R-L-C circuit if the resonant frequency is 7.125 MHz, L is 12.6 microhenrys and R is 22 kilohms is 39.

The Q of a parallel R-L-C circuit if the resonant frequency is 3.625 MHz, L is 42 microhenrys and R is 220 ohms is 0.23.

The Q of a parallel RLC circuit if the resonant frequency is 14.128 MHz, L is 4.7 microhenrys and R is 18 kilohms is 43.1.

The Q of a parallel RLC circuit if the resonant frequency is 14.225 MHz, L is 3.5 microhenrys and R is 10 kilohms is 31.9.

The Q of a parallel RLC circuit if the resonant frequency is 7.125 MHz, L is 10.1 microhenrys and R is 100 ohms is 0.221.

The Q of a parallel RLC circuit if the resonant frequency is 3.625 MHz, L is 3 microhenrys and R is 2.2 kilohms is 32.2.

## **Reactive power**

Reactive power is the term for an out-of-phase, nonproductive power associated with inductors and capacitors.

In a circuit that has both inductors and capacitors, reactive power goes back and forth between magnetic and electric fields, but is not dissipated.

The power used in a circuit can be less than the product of the magnitudes of the AC voltage and current because there is a phase angle greater than zero between the current and voltage.

## **Power factor**

Watt-less, nonproductive power is reactive power.

In a circuit where the AC voltage and current are out of phase, the true power can be determined by multiplying the apparent power times the power factor.

The power factor of an RL circuit having a 45 degree phase angle between the voltage and the current is 0.707.

The power factor of an RL circuit having a 30 degree phase angle between the voltage and the current is 0.866.

The power factor of an R-L circuit having a 60 degree phase angle between the voltage and the current is 0.5.

A power of 80 watts is consumed in a circuit having a power factor of 0.2 if the input is 100-V AC at 4 amperes.

The power consumed is 600 watts in a circuit having a power factor of 0.6 if the input is 200V AC at 5 amperes.

If the apparent power is 500 watts and the circuit has a power factor of 0.71 the power consumed is 355 watts.

## **Effective radiated power**

The effective radiated power of a repeater station with 50 watts transmitter power output, 4-dB feed line loss, 2-dB duplexer loss, 1-dB circulator loss and 6-dBd antenna gain is 39.7 watts.

The effective radiated power of a repeater station with 50 watts transmitter power output, 5-dB feed line loss, 3-dB duplexer loss, 1-dB circulator loss and 7-dBd antenna gain is 31.5 watts.

The effective radiated power of a station with 75 watts transmitter power output, 4-dB feed line loss and 10-dBd antenna gain is 299 watts.

The effective radiated power of a repeater station with 75 watts transmitter power output, 5-dB feed line loss, 3-dB duplexer loss, 1-dB circulator loss and 6-dBd antenna gain is 37.6 watts.

The effective radiated power of a station with 100 watts transmitter power output, 1-dB feed line loss and 6-dBd antenna gain is 316 watts.

The effective radiated power of a repeater station with 120 watts transmitter power output, 5-dB feed line loss, 3-dB duplexer loss, 1-dB circulator loss and 6-dBd antenna gain is 60 watts.

The effective radiated power of a repeater station with 100 watts transmitter power output, 5-dB feed line loss, 3-dB duplexer loss, 1-dB circulator loss and 10-dBd antenna gain is 126 watts.

The effective radiated power of a repeater station with 150 watts transmitter power output, 2-dB feed line loss, 2.2-dB duplexer loss and 7-dBd antenna gain is 286 watts.

The effective radiated power of a repeater station with 200 watts transmitter power output, 4-dB feed line loss, 3.2-dB duplexer loss, 0.8-dB circulator loss and 10-dBd antenna gain is 317 watts.

The effective radiated power of a repeater station with 200 watts transmitter power output, 2-dB feed line loss, 2.8-dB duplexer loss, 1.2-dB circulator loss and 7-dBd antenna gain is 252 watts.

### **System gains and losses**

Effective radiated power is the term that describes station output (including the transmitter, antenna and everything in between), when considering transmitter power and system gains and losses.

### **Photoconductive principles and effects**

Photoconductivity is the increased conductivity of an illuminated semiconductor junction.

The conductivity of a photoconductive material increases when light shines on it.

The resistance of a photoconductive material decreases when light shines on it.

The conductivity of a semiconductor junction increases when light shines on it.

An optocoupler is an LED and a phototransistor.

An optoisolator is an LED and a phototransistor.

An optical shaft encoder is an array of optocouplers whose light transmission path is controlled by a rotating wheel.

The resistance characteristic of a crystalline solid will change photoconductivity.

Cadmium sulfide will exhibit the greatest photoconductive effect when visible light shines on it.

Lead sulfide will exhibit the greatest photoconductive effect when infrared light shines on it.

A crystalline semiconductor is affected the most by photoconductivity.

A characteristic of optoisolators often used in power supplies is very high impedance between the light source and the phototransistor.

The characteristic of optoisolators that makes them suitable for use with a triac to form the solid-state equivalent of a mechanical relay for a 120 V AC household circuit is they provide a very high degree of electrical isolation between a control circuit and a power circuit.

**SUBELEMENT E6 -- CIRCUIT COMPONENTS [5 Exam Questions -- 5 Groups]**

**Semiconductor material: Germanium, Silicon, P-type, N-type**

Gallium arsenide is used as a semiconductor material in preference to germanium or silicon at microwave-range frequencies.

N-type of semiconductor material contains more free electrons than pure germanium or silicon crystals.

Holes are the majority charge carriers in P-type semiconductor material?

Acceptor impurity is the name given to an impurity atom that adds holes to a semiconductor crystal structure.

The alpha of a bipolar transistor is the change of collector current with respect to emitter current.

Silicon and germanium are two elements widely used in semiconductor devices that exhibit both metallic and nonmetallic characteristics.

P-type type of semiconductor material contains fewer free electrons than pure germanium or silicon crystals.

Free electrons are the majority charge carriers in N-type semiconductor material.

**Transistor types: NPN, PNP, junction, power**

In Figure E6-1, the schematic symbol, 1, is for a PNP transistor.

**Figure E6-1**

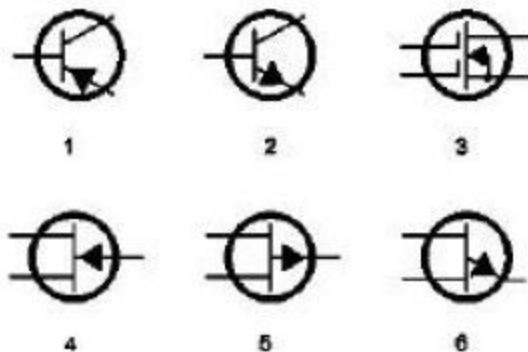

Alpha cutoff frequency is the term that indicates the frequency at which a transistor grounded base current gain has decreased to 0.7 of the gain obtainable at 1 kHz.

**Field-effect transistors (FETs): enhancement mode; depletion mode; MOS; CMOS; N-channel; P-channel**

The three terminals of a field-effect transistor are Gate, drain, source.

In comparing DC input impedance, a Field Effect Transistor (FET) has high input impedance; a bipolar transistor has low input impedance.

A depletion-mode FET is an FET that has a channel with no gate voltage applied; a current flows with zero gate voltage.

Many MOSFET devices have built-in gate-protective Zener diodes to prevent the gate insulation from being punctured by small static charges or excessive voltages.

The initials CMOS stand for Complementary metal-oxide semiconductor.

In Figure E6-2, the schematic symbol, 1, is for a P-channel junction FET.

In Figure E6-2, the schematic symbol, 4, is for an N-channel dual-gate MOSFET.

**Figure E6-2**

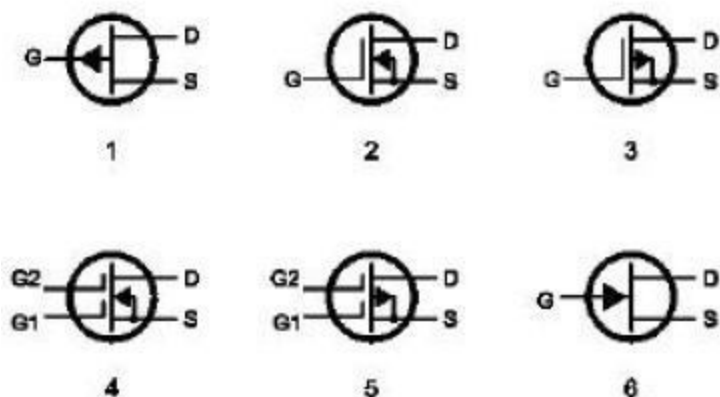

**Diodes: Zener, tunnel, varactor, hot-carrier, junction, point contact, PIN and light emitting**

The principal characteristic of a Zener diode is a constant voltage under conditions of varying current.

The principal characteristic of a tunnel diode is a negative resistance region.

A Tunnel diode is capable of both amplification and oscillation.

A Varactor semiconductor diode varies its internal capacitance as the voltage applied to its terminals varies.

Common uses of a hot-carrier diode are as VHF and UHF mixers and detectors.

Junction temperature limits the maximum forward current rating in a junction diode.

Structurally, the two main categories of semiconductor diodes are the PN junction and metal-semiconductor junction.

A common use for point contact diodes is as an RF detector. Junction diodes are rated for maximum forward current and PIV.

One common use for PIN diodes is as an RF switch.

Forward bias is required for an LED to produce luminescence.

In Figure E6-3, the schematic symbol, 1, is for a varactor diode.

In Figure E6-3, the schematic symbol, 5, is for a light-emitting diode.

**Figure E6-3**

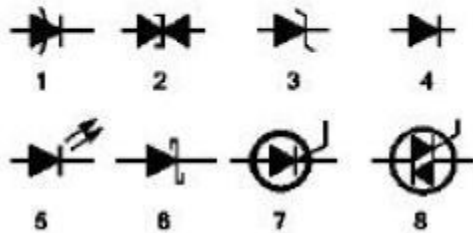

**Operational amplifiers (inverting amplifiers, noninverting amplifiers, voltage gain, frequency response, FET amplifier circuits, single-stage amplifier applications)**

The gain of a theoretically ideal operational amplifier does not vary with frequency.

An operational amplifier is a high-gain, direct-coupled differential amplifier whose characteristics are determined by components external to the amplifier.

The term op-amp input-offset voltage means the potential between the amplifier input terminals of the op-amp in a closed-loop condition.

The input impedance of a theoretically ideal op-amp is very high.

The output impedance of a theoretically ideal op-amp is very low.

The drain resistor essentially determines the output impedance of a FET common-source amplifier.

The voltage gain of 47 can be expected from the circuit in Figure E6-4 when  $R_1$  is 10 ohms and  $R_F$  is 470 ohms.

The voltage of the circuit shown in Figure E6-4 will be -2.3 volts if  $R_1$  is 1000 ohms and  $R_F$  is 10,000 ohms and 0.23 volts is applied to the input.

The voltage gain of 38 can be expected from the circuit in Figure E6-4 when  $R_1$  is 1800 ohms and  $R_F$  is 68 kilohms.

The voltage gain of 14 can be expected from the circuit in Figure E6-4 when  $R_1$  is 3300 ohms and  $R_F$  is 47 kilohms.

(Figure E6-4 can be found on the next page)

Figure E6-4

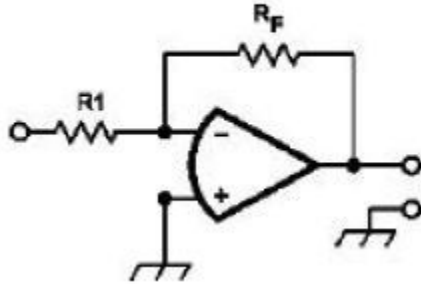

**Gates**

In Figure E6-5, the schematic symbol, 1, is for an AND gate.

In Figure E6-5, the schematic symbol, 2, is for a NAND gate.

In Figure E6-5, the schematic symbol, 3, is for an OR gate.

In Figure E6-5, the schematic symbol, 4, is for a NOR gate.

In Figure E6-5, the schematic symbol, 5, is for the NOT operation (inverter).

Figure E6-5

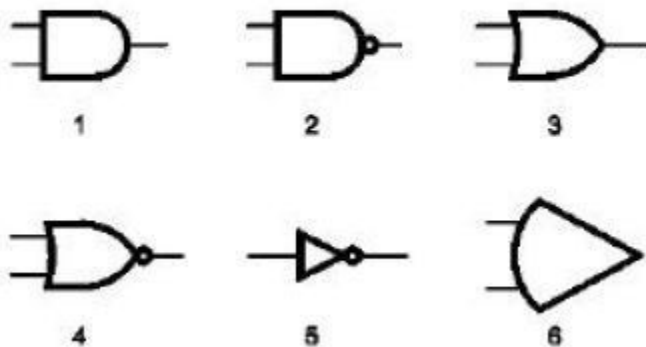

**Phase-locked loops**

A phase-locked loop circuit is used to recover audio from an FM voice signal.

The capture range of a phase-locked loop circuit is the frequency range over which the circuit can lock.

A phase-locked loop circuit is an electronic servo loop consisting of a phase detector, a low-pass filter and voltage-controlled oscillator.

The functions performed by a phase-locked loop are Frequency synthesis, FM demodulation.

### **TTL digital integrated circuits**

The recommended power supply voltage for TTL series integrated circuits is 5 volts.

The inputs of a TTL device assume a high-logic state if they are left open.

The level of input voltage, 2.0 to 5.5 volts, is high in a TTL device operating with a 5-volt power supply.

The level of input voltage, 0.0 to 0.8 volts, is low in a TTL device operating with a 5-volt power-supply.

### **CMOS digital integrated circuits**

Differential output is NOT a major advantage of CMOS over other devices.

CMOS digital integrated circuits have high immunity to noise on the input signal or power supply because the input switching threshold is about one-half the power supply voltage.

### **Vidicon and cathode-ray tube devices**

The electron beam is deflected in a vidicon by varying electromagnetic fields.

Cathode ray tube (CRT) persistence is the length of time the image remains on the screen after the beam is turned off.

If a cathode ray tube (CRT) is designed to operate with an anode voltage of 25,000 volts, if the anode voltage is increased to 35,000 volts the image size will decrease and the tube will produce X-rays.

Exceeding the anode voltage design rating can cause a cathode ray tube (CRT) to generate X-rays.

Electrostatic CRT deflection is better when high-frequency waves are to be displayed on the screen.

### **Charge-coupled devices (CCDs)**

A charge-coupled device (CCD) samples an analog signal and passes it in stages from the input to the output.

In a modern video camera a charge-coupled device (CCD) stores photogenerated charges as signals corresponding to pixels.

It is NOT true of a charge-coupled device (CCD) that it can be used as an analog-to-digital converter.

### **Liquid crystal displays (LCDs)**

The principle advantage of liquid-crystal display (LCD) devices is they consume low power.

A liquid-crystal display (LCD) is a display that uses a crystalline liquid to change the way light is refracted.

### **Toroids: permeability, core material, selecting, winding**

Core permeability is the material property determines the inductance of a toroidal inductor with a 10-turn winding.

By careful selection of core material, toroidal cores can produce useful inductors over the frequency range from 100 Hz to at least 1000 MHz.

One important reason for using powdered-iron toroids rather than ferrite toroids in an inductor is powdered-iron toroids generally have better temperature stability.

Ferrite beads are commonly used as VHF and UHF parasitic suppressors at the input and output terminals of transistorized HF amplifiers.

A primary advantage of using a toroidal core instead of a solenoidal core in an inductor is toroidal cores contain most of the magnetic field within the core material.

To produce a 1-mH inductor using a ferrite toroidal core that has an inductance index (A L) value of 523 millihenrys/1000 turns, 43 turns will be required.

To produce a 5-microhenry inductor using a powdered-iron toroidal core that has an inductance index (A L) value of 40 microhenrys/100 turns, 35 turns will be required.

One important reason for using ferrite toroids rather than powdered-iron toroids in an inductor is Ferrite toroids generally require fewer turns to produce a given inductance value.

### **Quartz crystal (frequency determining properties as used in oscillators and filters)**

For single-sideband phone emissions, the bandwidth of a good crystal lattice band-pass filter would be 2.1 kHz at -6 dB.

For double-sideband phone emissions, the bandwidth of a good crystal lattice band-pass filter would be 6 kHz at -6 dB.

A crystal lattice filter is a filter with narrow bandwidth and steep skirts made using quartz crystals.

The technique used to construct low-cost, high-performance crystal ladder filters is measure crystal frequencies and carefully select units with a frequency variation of less than 10% of the desired filter bandwidth.

The relative frequencies of the individual crystals has the greatest effect in helping determine the bandwidth and response shape of a crystal ladder filter.

The piezoelectric effect is the physical deformation of a crystal by the application of a voltage.

### **Monolithic amplifiers (MMICs)**

A monolithic microwave integrated circuit (MMIC) amplifier device consists of a small pill sized package with an input lead, an output lead and 2 ground leads.

Microstrip construction is the typical construction technique amateurs use when building an amplifier for the microwave bands containing a monolithic microwave integrated circuit (MMIC).

The characteristic impedance of circuits in which MMICs are designed to work is 50 ohms.

The typical noise figure of a monolithic microwave integrated circuit (MMIC) amplifier is approximately 3.5 to 6 dB.

The operating bias voltage supplied to a monolithic microwave integrated circuit (MMIC) that uses four leads is through a resistor and RF choke connected to the amplifier output lead.

The DC power from a voltage source is fed to monolithic microwave integrated circuits (MMIC) through a resistor.

The supply voltage that monolithic microwave integrated circuits (MMIC) amplifiers typically require is 12 volts DC.

The most common package for inexpensive monolithic microwave integrated circuit (MMIC) amplifiers are Plastic packages.

**SUBELEMENT E7 -- PRACTICAL CIRCUITS [7 Exam Questions -- 7 Groups]**

**Digital logic circuits:**

**Flip flops**

A flip-flop is a bistable multivibrator circuit.

Two output level changes are obtained for every two trigger pulses applied to the input of a "T" flip-flop circuit.

Two flip-flops are required to divide a signal frequency by 4.

**Astable and monostable multivibrators**

The frequency of an AC signal can be divided electronically by a digital bistable multivibrator circuit.

The characteristic function of an astable multivibrator is it alternates between two unstable states.

The characteristic function of a monostable multivibrator is it switches momentarily to the opposite binary state and then returns after a set time to its original state.

**Gates (AND, NAND, OR, NOR)**

An AND gate produces a logic "1" at its output only if all inputs are logic "1".

A NAND gate produces logic "0" at its output only when all inputs are logic "1".

An OR gate produces logic "1" at its output if any input is or all inputs are logic "1".

A NOR gate produces a logic "0" at its output if any input is or all inputs are logic "1"

A truth table is a list of input combinations and their corresponding outputs that characterize the function of a digital device.

**Positive and negative logic**

In a positive-logic circuit, a high level is used to represent logic 1.

In a negative-logic circuit, a low level is used to represent logic 1.

**Amplifier circuits: Class A, Class AB, Class B, Class C, amplifier operating efficiency (i.e., DC input versus PEP), transmitter final amplifiers**

A Class AB amplifier operates for a portion more than 180 degrees but less than 360 degrees of a signal cycle.

A Class C amplifier provides the highest efficiency.

Even-order harmonics can be reduced or prevented in transmitter amplifiers by using a push-pull amplifier.

**Amplifier circuits: tube, bipolar transistor, FET**

A bipolar-transistor, common-emitter Class A power amplifier should be operated below the saturation region on the load line for best efficiency and stability.

Parasitic oscillations can be eliminated from a power amplifier by neutralization.

Distortion can occur when a nonlinear amplifier is used with a single-sideband phone transmitter.

A vacuum-tube power amplifier can be neutralized by feeding back an out-of-phase component of the output to the input.

The procedure for tuning a vacuum-tube power amplifier, having an output pi-network, is alternately increase the plate current with the loading capacitor and dip the plate current with the tuning capacitor.

In Figure E7-1, the purpose of R1 and R2 is Fixed bias.

In Figure E7-1, the purpose of C3 is Emitter bypass.

In Figure E7-1, the purpose of R3 is Self bias.

A common emitter amplifier circuit is shown in Figure E7-1.

In Figure E7-1, the purpose of C1 is input coupling.

**Figure E7-1**

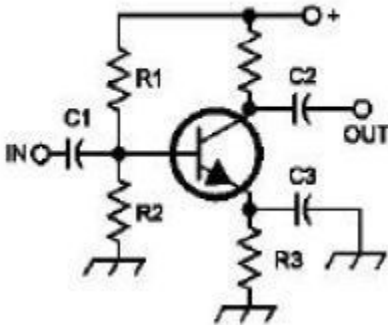

In Figure E7-2, the purpose of R is Emitter load.

In Figure E7-2, the purpose of C2 is Output coupling.

**Figure E7-2**

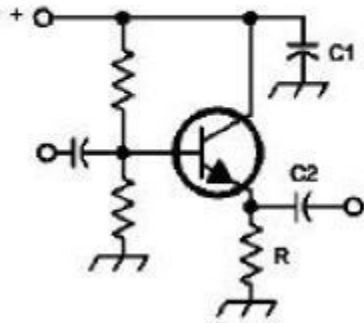

The purpose of D1 in the circuit shown in Figure E7-3 is Voltage reference.

The purpose of Q1 in the circuit shown in Figure E7-3 is it increases the current-handling capability.

The purpose of C2 in the circuit shown in Figure E7-3 is it bypasses hum around D1.

A Linear voltage regulator circuit is shown in Figure E7-3.

The purpose of C1 in the circuit shown in Figure E7-3 is it filters the supply voltage.

The purpose of C3 in the circuit shown in Figure E7-3 is it prevents self-oscillation.

The purpose of R1 in the circuit shown in Figure E7-3 is it supplies current to D1.

The purpose of R2 in the circuit shown in Figure E7-3 is it provides a constant minimum load for Q1.

**Figure E7-3**

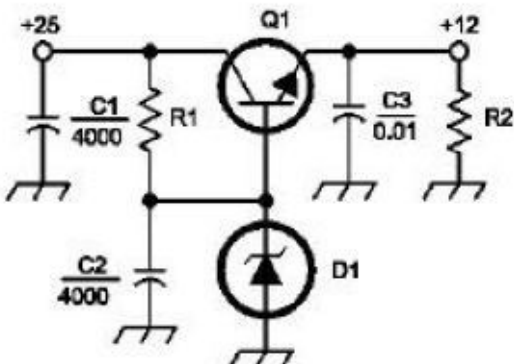

### **Impedance-matching networks: Pi, L, Pi-L**

A network transforms one impedance to another by canceling the reactive part of impedance and changes the resistive part.

The capacitors and inductors of a low-pass filter pi-network are arranged between the network's input and output for gradual passband rolloff with extreme stop-band ripple.

A pi-network is a network consisting of one inductor and two capacitors or two inductors and one capacitor.

A pi-L-network is a network consisting of two inductors and two capacitors.

A Pi-L-network provides the greatest harmonic suppression.

An L-network is a network consisting of an inductor and a capacitor.

A T-network with series capacitors and a parallel (shunt) inductor transforms impedances and is a high-pass filter.

A pi-L-network has the advantage of greater harmonic suppression over a pi-network for impedance matching between the final amplifier of a vacuum-tube type transmitter and a multiband antenna.

### **Filter circuits: constant K, M-derived, band-stop, notch, crystal lattice, pi-section, T-section, L-section, Butterworth, Chebyshev, elliptical**

A Chebyshev filter is described as having ripple in the passband and a sharp cutoff.

The distinguishing features of an elliptical filter are extremely sharp cutoff, with one or more infinitely deep notches in the stop band.

### **Filter applications (audio, IF, digital signal processing {DSP})**

You would use an audio notch filter to attenuate an interfering carrier signal while receiving an SSB transmission.

You would use an audio notch filter to attenuate an interfering carrier signal while receiving an SSB transmission.

Typical SSB receiver IF filters lack the linear phase response characteristic that is important to digital communications.

A digital signal processing audio filter, called an adaptive filter, might be used to remove unwanted noise from a received SSB signal.

A digital signal processing filter, called a Hilbert-transform filter, might be used in generating an SSB signal.

A cavity filter would be the best to use in a 2-meter repeater duplexer.

### **Oscillators: types, applications, stability**

The three major oscillator circuits often used in Amateur Radio equipment are Colpitts, Hartley and Pierce.

Colpitts and Hartley oscillator circuits are commonly used in a VFO.

In order for a circuit to oscillate it must have positive feedback sufficient to overcome losses.

The positive feedback is coupled to the input in a Hartley oscillator through a tapped coil.

The positive feedback is coupled to the input in a Colpitts oscillator through a capacitive divider.

The positive feedback is coupled to the input in a Pierce oscillator through a quartz crystal.

A very stable reference oscillator is normally used as part of a phase-locked loop (PLL) frequency synthesizer because any phase variations in the reference oscillator signal will produce phase noise in the synthesizer output.

### **Voltage-regulator circuits: discrete, integrated and switched mode**

One characteristic of a linear electronic voltage regulator is the conduction of a control element is varied in direct proportion to the load current to maintain a constant output voltage.

One characteristic of a switching electronic voltage regulator is the control device is switched on or off, with the duty cycle automatically adjusted to maintain a constant average output voltage.

A Zener diode device is typically used as a stable reference voltage in a linear voltage regulator.

A series linear regulator is used in applications requiring efficient use of the primary power source.

A shunt linear voltage regulator is used in applications requiring a constant load on the unregulated voltage source.

Zener diode voltages of 5.6 volts will result in the best temperature stability for a voltage reference.

The important characteristics of a three-terminal regulator are Maximum and minimum input voltage, maximum and minimum output current and maximum output voltage.

A Zener diode voltage regulator limits the voltage drop across its junction when a specified current passes through it in the reverse-breakdown direction.

### **Modulators: reactance, phase, balanced**

A F3E FM-phone emission is produced with a reactance modulator on the oscillator.

A reactance modulator acts as a variable inductance or capacitance to produce FM signals.

A phase modulator varies the tuning of an amplifier tank circuit to produce PM signals.

A single-sideband phone signal can be generated by using a balanced modulator followed by a filter.

A pre-emphasis audio shaping network is added at a transmitter to proportionally attenuate the lower audio frequencies, giving an even spread to the energy in the audio band.

A de-emphasis audio shaping network is added at a receiver to restore proportionally attenuated lower audio frequencies.

An FM-phone signal can be produced by using a reactance modulator on an oscillator.

### **Detectors**

The process of detection is the recovery of the intelligence from a modulated RF signal.

The principle of detection in a diode detector is rectification and filtering of RF.

A product detector mixes an incoming signal with a locally generated carrier.

FM-phone signals are detected with a frequency discriminator.

A frequency discriminator is a circuit for detecting FM signals.

### **Mixer stages**

The mixing process is the combination of two signals to produce sum and difference frequencies.

The principal frequencies that appear at the output of a mixer circuit are the original frequencies and the sum and difference frequencies.

Spurious mixer products are generated in a receiver when an excessive amount of signal energy reaches the mixer circuit.

### **Frequency synthesizers**

A phase-locked loop frequency synthesizer circuit uses a stable voltage-controlled oscillator, programmable divider, phase detector, loop filter and a reference frequency source.

A direct digital frequency synthesizer circuit uses a phase accumulator, lookup table, digital to analog converter and a low-pass antialias filter.

The main blocks of a direct digital frequency synthesizer are a phase accumulator, lookup table, digital to analog converter and a low-pass antialias filter.

The amplitude values that represent a sine-wave output are contained in the lookup table of a direct digital frequency synthesizer.

The major spectral impurity components of direct digital synthesizers are spurs at discrete frequencies.

The major spectral impurity components of phase-locked loop synthesizers are broadband noise.

### **Digital frequency divider circuits**

The purpose of a prescaler circuit divides an HF signal so a low-frequency counter can display the operating frequency.

A decade counter digital IC has 10 states.

The function of a decade counter digital IC is it produces one output pulse for every ten input pulses.

Two flip-flops are required in a 100-kHz crystal-controlled marker generator to provide markers at 50 and 25 kHz.

If a 1-MHz oscillator is used with a divide-by-ten circuit to make a marker generator, the output will be a 100-kHz signal with harmonics every 100 kHz.

### **Frequency marker generators**

A crystal-controlled marker generator is a high-stability oscillator that generates a series of reference signals at known frequency intervals.

A sinusoidal crystal oscillator circuit does NOT make a good marker generator.

The purpose of a marker generator is to provide a means of calibrating a receiver's frequency settings.

### **Frequency counters**

The accuracy of a frequency counter depends on the internal crystal reference.

A frequency counter counts the number of input pulses in a specific period of time to determine the frequency of a signal.

The purpose of a frequency counter is to indicate the frequency of the strongest input signal which is within the counter's frequency range.

## **Active audio filters:**

### **Characteristics**

The values of capacitances and resistances external to the op-amp determine the gain and frequency characteristics of an op-amp RC active filter.

The filter shape, as measured in the frequency domain causes ringing in a filter.

The advantages of using an op-amp instead of LC elements in an audio filter is that Op-amps exhibit gain rather than insertion loss.

Unwanted ringing and audio instability can be prevented in a multisection op-amp RC audio filter circuit by restricting both gain and Q.

Filter bandwidth must be selected when selecting the resistor and capacitor values for an RC active filter using an op-amp.

The principal uses of an op-amp RC active filter in amateur circuitry are audio filters used for receivers.

An op-amp RC active audio filter should be placed in the low-level audio stages of an amateur receiver.

### **Basic circuit design**

Polystyrene capacitors should be used in a high-stability op-amp RC active filter circuit.

When designing an op-amp RC active filter for a given frequency range and Q, capacitors with unusual capacitance values are not widely available, so standard values are used to begin the calculations then the external resistance values are calculated.

When designing an op-amp RC active filter for a given frequency range and Q, standard capacitor values are chosen first, the resistances are calculated, then resistors of the nearest standard value are used.

### **Preselector applications**

The design of a preselector involves a trade-off between bandwidth and insertion loss.

**SUBELEMENT E8 - SIGNALS AND EMISSIONS [4 Exam Questions -- 4 Groups]**

**AC waveforms: sine wave, square wave, sawtooth wave**

The period of a wave is the time required to complete one cycle.

Starting at a positive peak, a sine wave crosses the zero axis 2 times in one complete cycle.

All odd harmonic sine waves are added to a fundamental frequency make up a square wave.

A square wave is made up of a sine wave of a fundamental frequency and all its odd harmonics.

A square wave abruptly changes back and forth between two voltage levels and remains an equal time at each level.

A square wave has a rise time significantly faster than the fall time (or vice versa).

A sawtooth wave is a wave with a straight line rise time faster than the fall time (or vice versa).

A sawtooth wave is made up of sine waves of a fundamental frequency and all harmonics.

**AC measurements: peak, peak-to-peak and root-mean-square (RMS) value, peak-envelope-power (PEP) relative to average**

The peak voltage at a common household electrical outlet is 170 volts.

The peak-to-peak voltage at a common household electrical outlet is 340 volts.

The RMS voltage at a common household electrical power outlet is 120-V AC.

The RMS value of a 340-volt peak-to-peak pure sine wave is 120-V AC.

The equivalent to the root-mean-square value of an AC voltage is the DC voltage causing the same heating in a given resistor as the RMS AC voltage of the same value.

The most accurate way of measuring the RMS voltage of a complex waveform is by measuring the heating effect in a known resistor.

For many types of voices, the approximate ratio of PEP to average power during a modulation peak in a single-sideband phone signal is 2.5 to 1.

In a single-sideband phone signal, the speech characteristics determine the PEP-to-average power ratio.

The approximate DC input power to a Class B RF power amplifier stage in an FM-phone transmitter is 2500 watts when the PEP output power is 1500 watts.

The approximate DC input power to a Class AB RF power amplifier stage in an unmodulated carrier transmitter is 1000 watts when the PEP output power is 500 watts.

### **FCC emission designators versus emission types**

If the first symbol of an ITU emission designator is J, representing a single-sideband, suppressed-carrier signal, information about the type of modulation of the main carrier is described.

If the second symbol of an ITU emission designator is 1, representing a single channel containing quantized, or digital information, information about the nature of signals modulating the main carrier is described.

If the third symbol of an ITU emission designator is D, representing data transmission, telemetry or telecommand, information about the type of information to be transmitted is described.

The three most-used symbols of an ITU emission designator are Type of modulation, nature of the modulating signal and type of information to be transmitted.

If the first symbol of an ITU emission designator is G, representing a phase-modulated signal, information about the type of modulation of the main carrier is described.

### **Modulation symbols and transmission characteristics/ Modulation methods**

Emission A3C is Facsimile.

A3C is produced when an AM transmitter is modulated by a facsimile signal.

Emission F3F is television.

J3F is produced when an SSB transmitter is modulated by a slow-scan television signal.

A facsimile transmission produces printed pictures by electrical means.

### **Modulation index**

The modulation index of a phase-modulated emission does not depend on the RF carrier frequency.

In an FM-phone signal having a maximum frequency deviation of 3000 Hz either side of the carrier frequency, the modulation index is 3 when the modulating frequency is 1000 Hz.

The modulation index of an FM-phone transmitter producing a maximum carrier deviation of 6 kHz when modulated with a 2-kHz modulating frequency is 3.

In an FM-phone signal, Modulation index is the term for the ratio between the deviation of the frequency modulated signal and the modulating frequency.

### **Deviation ratio**

The deviation ratio of an FM-phone signal having a maximum frequency swing of plus or minus 5 kHz and accepting a maximum modulation rate of 3-kHz is 1.67.

Deviation ratio is the ratio of the maximum carrier frequency deviation to the highest audio modulating frequency.

The deviation ratio of an FM-phone signal having a maximum frequency swing of plus or minus 7.5 kHz and accepting a maximum modulation rate of 3.5 kHz is 2.14.

### **Pulse modulation: width; position**

In a pulse width-modulation system, the transmitter's peak power is much greater than its average power because the signal duty cycle is less than 100%.

One way that voice is transmitted in a pulse-width modulation system is a standard pulse is varied in duration by an amount depending on the voice waveform at that instant.

In a pulse-position modulation system, the modulating signal varies the time at which each pulse occurs.

In a pulse-width modulation system, the modulating signal varies the Pulse duration.

The pulses of a pulse-modulated signal are usually transmitted such that a pulse of relatively short duration is sent; a relatively long period of time separates each pulse.

### **Digital signals: including CW**

Morse code is a digital code consisting of elements having unequal length.

Some of the differences between the Baudot digital code and ASCII are:

- Baudot uses five data bits per character, ASCII uses seven
- Baudot uses two characters as shift codes, ASCII has no shift code

One advantage of using the ASCII code for data communications is that it is possible to transmit both upper and lower case text.

Computerized high speed CW (HSCW) is a digital communications system that is well suited for meteor-scatter Communications at times other than during meteor showers.

Mode A AMTOR uses an error control system where the receiving station automatically requests repeats when needed.

Mode B AMTOR uses an error control system where each character is sent twice.

### **Digital signal information rate vs Bandwidth**

The necessary bandwidth of a 13-WPM international Morse code emission A1A transmission is approximately 52 Hz.

The necessary bandwidth for a 170-hertz shift, 300-baud ASCII emission J2D transmission is 0.5 kHz.

The necessary bandwidth of a 1000-Hz shift, 1200-baud ASCII emission F1D transmission is 2400 Hz.

The necessary bandwidth of a 4800-Hz frequency shift, 9600-baud ASCII emission F1D transmission is 15.36 kHz.

### **Spread-spectrum communications**

The term, Spread-spectrum communication, describes a wide-bandwidth communications system in which the RF carrier varies according to some predetermined sequence.

Spread-spectrum communications Frequency hopping technique alters the center frequency of a conventional carrier many times per second in accordance with a pseudo-random list of channels.

Spread-spectrum communications Direct sequence technique uses a very fast binary bit stream to shift the phase of an RF carrier.

A binary linear-feedback shift register controls the spreading sequence of an amateur spread-spectrum transmission.

Only signals using the correct spreading sequence are received makes spread-spectrum communications resistant to interference.

Spread-spectrum signals appear only as low-level noise in conventional receivers which reduces interference from spread-spectrum transmitters to conventional communications in the same band.

### **Peak amplitude (positive and negative)**

Peak positive voltage is the term for the amplitude of the maximum positive excursion of a signal as viewed on an oscilloscope.

### **Peak-to-peak values: measurements**

Peak-to-peak voltage is the easiest voltage amplitude dimension to measure by viewing a pure sine wave signal on an oscilloscope.

The relationship between the peak-to-peak voltage and the peak voltage amplitude in a symmetrical waveform is a ratio of 2:1.

The Peak voltage input-amplitude parameter is valuable in evaluating the signal-handling capability of a Class A amplifier.

The PEP output of a transmitter that has a maximum peak of 30 volts to a 50-ohm load as observed on an oscilloscope is 9 watts.

The advantage of using a peak-reading voltmeter to monitor the output of a single-sideband transmitter is that it would be easy to calculate the PEP output of the transmitter.

The average power dissipated by a 50-ohm resistive load during one complete RF cycle having a peak voltage of 35 volts is 12.2 watts.

If an RMS reading AC voltmeter reads 65 volts on a sinusoidal waveform, the peak-to-peak voltage is 184 volts.

If an RMS reading voltmeter reads 34 volts on a sinusoidal waveform, the peak voltage is 48 volts.

### **Electromagnetic radiation**

An electromagnetic wave is a wave consisting of an electric field and a magnetic field at right angles to each other.

Changing electric and magnetic fields propagate the energy across a vacuum best describes electromagnetic waves traveling in free space.

Electromagnetic waves travel at a speed of approximately 300 million meters per second in free space.

### **Wave polarization**

Circularly polarized electromagnetic waves are waves with a rotating electric field.

The polarization of an electromagnetic wave is Vertical if its magnetic field is parallel to the surface of the Earth.

The polarization of an electromagnetic wave is Horizontal if its magnetic field is perpendicular to the surface of the Earth.

### **Signal-to-noise (S/N) ratio**

Atmospheric noise is the primary source of noise that can be heard in an HF-band receiver with an antenna connected.

To ensure you do not exceed the maximum allowable power, a peak-reading wattmeter would be used to monitor the output signal of a properly adjusted single-sideband transmitter.

## **SUBELEMENT E9 -- ANTENNAS [5 Exam Questions -- 5 Groups]**

### **Isotropic radiators:**

#### **Definition**

A theoretical radiator used to compare other antennas describes an isotropic radiator.

A theoretical reference antenna, Isotropic radiator, provides a comparison for antenna measurements.

#### **Used as a standard for comparison**

It is useful to refer to an isotropic radiator when comparing the gains of directional antennas.

A 1/2-wavelength dipole has about 2.1 db of gain over an isotropic radiator.

An Isotropic radiator has no gain in any direction.

An antenna has about 3.9 dB of gain over a 1/2-wavelength dipole when it has 6 dB gain over an isotropic radiator.

An antenna has about 9.9 dB of gain over a 1/2-wavelength dipole when it has 12 dB gain over an isotropic radiator.

#### **Radiation pattern**

An isotropic radiator has no directivity at all.

A sphere with the antenna in the center describes the radiation pattern of an isotropic radiator.

### **Basic antenna parameters:**

#### **Radiation resistance and reactance (including wire dipole and folded dipole)**

The radiation resistance of an antenna is the equivalent resistance that would dissipate the same amount of power as that radiated from an antenna.

One would need to know the feed point impedance of an antenna to match impedances for maximum power transfer.

Antenna location with respect to nearby objects and the conductors' length/diameter ratio factors determine the radiation resistance of an antenna.

Radiation resistance plus ohmic resistance is included in the total resistance of an antenna system.

A folded dipole antenna is a dipole whose ends are connected by a one-half wavelength piece of wire.

## Gain

Antenna gain is the numerical ratio relating the radiated signal strength of an antenna to that of another antenna.

## Beamwidth

Antenna bandwidth is the frequency range over which an antenna can be expected to perform well.

The approximate beamwidth of a beam antenna can be determined by noting the two points where the signal strength of the antenna is down 3 dB from the maximum signal point and compute the angular difference.

## Efficiency

Antenna efficiency is the term for the ratio of the radiation resistance of an antenna to the total resistance of the system.

Antenna efficiency is calculated as:

$$(\text{Radiation Resistance} / \text{Total Resistance}) \times 100\%$$

The efficiency of an HF grounded vertical antenna can be made comparable to that of a half-wave dipole antenna by installing a good ground radial system.

## Free-space antenna patterns:

### **E and H plane patterns (i.e., azimuth and elevation in free-space)**

The orientation of its electric field (E Field) determines the free-space polarization of an antenna.

In the free-space H-Field radiation pattern shown in Figure E9-1, the 3-dB beamwidth is 50 degrees.

In the free-space H-Field pattern shown in Figure E9-1, the front-to-back ratio is 18 dB.

In the free-space H-field pattern shown in Figure E9-1, the front-to-side ratio is 14 dB.

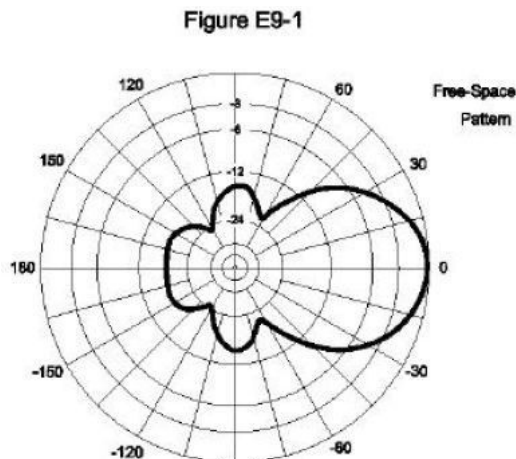

### **Gain as a function of pattern**

The following information is needed to accurately evaluate the gain of an antenna:

- Radiation resistance
- E-Field and H-Field patterns
- Loss resistance
- (All of these choices)

Since the dielectric constant may vary significantly it is NOT an important reason to evaluate a gain antenna across the whole frequency band for which it was designed.

If a Yagi antenna is designed solely for maximum forward gain the feed-point impedance becomes very low.

If the boom of a Yagi antenna is lengthened and the elements are properly retuned, the gain increases.

### **Antenna design (computer modeling of antennas)**

A type of computer program, Method of Moments, is commonly used for modeling antennas.

The principle of a Method of Moments analysis is a wire is modeled as a series of segments, each having a distinct value of current.

### **Radiation patterns/ Phased vertical antennas**

The low-angle radiation increases for the far-field elevation pattern of a vertically polarized antenna by being mounted over seawater versus rocky ground.

If only a modest on-ground radial system can be used with an eighth-wavelength-high, inductively loaded vertical antenna, the best compromise to minimize near-field losses would be a wire-mesh screen at the antenna base, an eighth-wavelength square.

The electric field would be oriented horizontally for a Yagi with three elements mounted parallel to the ground.

The conductivity and dielectric constant of the soil strongly affects the shape of the far-field, low-angle elevation pattern of a vertically polarized antenna.

Elevated-radial counterpoises are popular with vertically polarized antennas because they reduce the near-field ground losses, compared to on-ground radial systems using more radials.

The radiation pattern of two 1/4-wavelength vertical antennas spaced 1/2-wavelength apart and fed 180 degrees out of phase is a Figure-8 end-fire in line with the antennas.

The radiation pattern of two 1/4-wavelength vertical antennas spaced 1/4-wavelength apart and fed 90 degrees out of phase is an Unidirectional cardioid.

The radiation pattern of two 1/4-wavelength vertical antennas spaced 1/2-wavelength apart and fed in phase is a Figure-8 broadside to the antennas.

The radiation pattern of two 1/4-wavelength vertical antennas spaced 1/4-wavelength apart and fed 180 degrees out of phase is a Figure-8 end-fire in line with the antennas.

The radiation pattern for two 1/4-wavelength vertical antennas spaced 1/8-wavelength apart and fed 180 degrees out of phase is a Figure-8 end-fire in line with the antennas.

The radiation pattern for two 1/4-wavelength vertical antennas spaced 1/4-wavelength apart and fed in phase is Elliptical.

An antenna elevation pattern over real ground is shown in Figure E9-2.

In the H field antenna radiation pattern shown in Figure E9-2, the elevation angle of the peak response is 7.5 degrees.

In the H field antenna radiation pattern shown in Figure E9-2, the front-to-back ratio is 28 dB.

In the H field antenna radiation pattern shown in Figure E9-2, 4 elevation lobes appear in the forward direction.

**Figure E9-2**

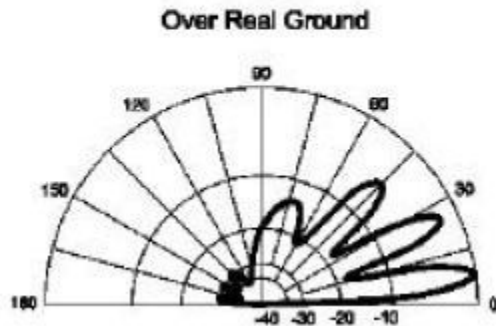

### **Beverage antennas**

One characteristic of a Beverage antenna is for best performance it should be longer than one wavelength.

### **Rhombic antennas**

Bidirectional; four-sided, each side approximately one wavelength long; open at the end opposite the transmission line connection is the best description of a resonant rhombic antenna.

Wide frequency range, high gain and high front-to-back ratio are the advantages of a terminated rhombic antenna.

A large area and four sturdy supports for proper installation are the disadvantages of a terminated rhombic antenna for the HF bands.

The effect of a terminating resistor on a rhombic antenna is it changes the radiation pattern from essentially bidirectional to essentially unidirectional.

A terminated rhombic antenna is a unidirectional antenna terminated in a resistance equal to its characteristic impedance.

#### **Space and satellite communications antennas: gain; beamwidth; tracking**

Height, transmitter power and antennas of satellite are factors that determine the receiving antenna gain required at an amateur satellite station in earth operation.

Satellite antennas and height, satellite receiver sensitivity are factors that determine the EIRP required by an amateur satellite station in earth operation.

The gain of a parabolic dish antenna increases 6 dB when the operating frequency is doubled.

A satellite communications antenna system for earth operation needs to have rotators for both azimuth and elevation control in order to track the satellite as it orbits the earth.

The approximate beamwidth of a symmetrical pattern antenna with a gain of 20 dB as compared to an isotropic radiator is 20 degrees.

The beamwidth of an antenna decreases as the gain is increased.

The beamwidth of a symmetrical pattern antenna with a gain of 30 dB as compared to an isotropic radiator is 6.4 degrees.

The beamwidth of a symmetrical pattern antenna with a gain of 15 dB as compared to an isotropic radiator is 36 degrees.

The beamwidth of a symmetrical pattern antenna with a gain of 12 dB as compared to an isotropic radiator is 51 degrees.

Circular polarization can be produced using linearly polarized antennas by arranging two Yagis perpendicular to each other, with the driven elements in the same plane, fed 90 degrees out of phase.

#### **Losses in real antennas and matching: resistivity losses, losses in resonating elements (loading coils, matching networks, etc. {i.e., mobile, trap}); SWR bandwidth; efficiency**

For a shortened vertical antenna, a loading coil should be placed near the center of the vertical radiator to minimize losses and produce the most effective performance.

An HF mobile antenna loading coil should have a high ratio of reactance to resistance to minimize losses.

A disadvantage of using a trap antenna is it will radiate harmonics.

In a 3-element Yagi, the driven element reactance must be tuned capacitive to use a hairpin matching system.

An L network is the equivalent lumped-constant network for a hairpin matching system on a 3-element Yagi.

The bandwidth of an antenna is decreases as it is shortened through the use of loading coils.

Improved radiation efficiency is an advantage of using top loading in a shortened HF vertical antenna.

The approximate input terminal impedance at the center of a folded dipole antenna is 300 ohms.

A loading coil is often used with an HF mobile antenna to tune out the capacitive reactance.

An advantage of using a trap antenna is that it may be used for multi-band operation.

The resistance decreases and the capacitive reactance increases at the base feed-point of a fixed length HF mobile antenna as the frequency of operation is lowered.

#### **Matching antennas to feed lines**

The delta matching system matches a high-impedance transmission line to a lower impedance antenna by connecting the line to the driven element in two places, spaced a fraction of a wavelength each side of element center.

The gamma matching system matches an unbalanced feed line to an antenna by feeding the driven element both at the center of the element and at a fraction of a wavelength to one side of center.

The stub impedance matching system uses a short perpendicular section of transmission line connected to the feed line near the antenna.

The approximate capacitance of the resonating capacitor in a gamma matching circuit on a Yagi beam antenna for the 20-meter band is 140 pF.

The approximate capacitance of the resonating capacitor in a gamma matching circuit on a Yagi beam antenna for the 10-meter band is 70 pF.

#### **Characteristics of open and shorted feed lines: 1/8 wavelength; 1/4 wavelength; 1/2 wavelength**

A 1/8-wavelength transmission line presents an inductive reactance to a generator when the line is shorted at the far end.

A 1/8-wavelength transmission line presents a capacitive reactance to a generator when the line is open at the far end.

A 1/4-wavelength transmission line presents a very low impedance to a generator when the line is open at the far end.

A 1/4-wavelength transmission line presents a very high impedance to a generator when the line is shorted at the far end.

A 1/2-wavelength transmission line presents a very low impedance to a generator when the line is shorted at the far end.

A 1/2-wavelength transmission line presents a very high impedance to a generator when the line is open at the far end.

**Feed lines: coax versus open-wire; velocity factor; electrical length; transformation characteristics of line terminated in impedance not equal to characteristic impedance; Use of antenna analyzers**

An SWR measurement greater than 1:1 describes a mismatched transmission line.

The Reflection coefficient parameter best describes the interactions at the load end of a mismatched transmission line.

Velocity factor is the term for the ratio of the actual velocity at which a signal travels through a transmission line to the speed of light in a vacuum.

The velocity factor of a transmission line is the velocity of the wave on the transmission line divided by the velocity of light in a vacuum.

Dielectrics in the line determine the velocity factor in a transmission line.

The physical length of a coaxial cable transmission line is shorter than its electrical length because RF energy moves slower along the coaxial cable.

The typical velocity factor for a coaxial cable with polyethylene dielectric is 0.66.

Assuming a velocity factor of 0.66, the physical length of a typical coaxial transmission line that is electrically one-quarter wavelength long at 14.1 MHz would be 3.5 meters.

Assuming a velocity factor of 0.95, the physical length of a parallel conductor feed line that is electrically one-half wavelength long at 14.10 MHz would be 10 meters.

A 450-ohm ladder line will have lower loss in dB/100 feet at 50 MHz, as compared to 0.195-inch-diameter coaxial cable (such as RG-58).

Assuming a velocity factor of 0.66, the physical length of a typical coaxial transmission line that is electrically one-quarter wavelength long at 7.2 MHz would be 6.9 meters.